



TECHNICAL MANUAL

Maintenance and Operation Instructions



ROTARY VANES

Compressors / Vacuum pumps

R / RFL G
P / PFL



CAUTION

1. Avoid impacts and accidental fall when handling the machine either packed or unpacked.
2. Prior to installation and start-up, please read the "TECHNICAL Manual". Special attention must be paid to all safety instructions included in the manual..
3. Write down Type and Serial No. of the machine on page 02 and keep the "Technical Manual" with the Plant Documents.

EN

Original Manual

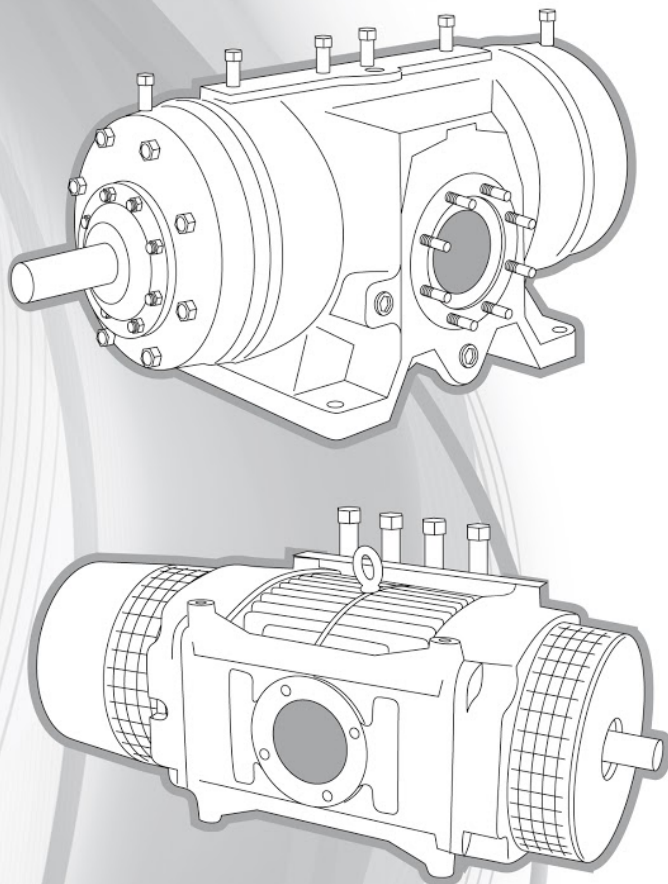

TECHNICAL MANUAL

Rotary Vanes | R/RFL G | P/PFL



WARNING

1. Avoid impacts and accidental fall when handling the machine either packed or unpacked.
2. Prior to installation and start-up, please read the "TECHNICAL Manual". Special attention must be paid to all safety instructions included in the manual.
3. For air-cooled machines (RF, RFL, PF, PFL series), please omit chapter 5.2 referring to the water-cooling system.
4. Put in this Page the MACHine Identification Nameplate Stick.

**MACHINE
IDENTIFICATION
STICKER**



TECHNICAL MANUAL

Rotary Vanes | R/RFL G | P/PFL

INDEX GENERAL

1. General
 2. EC Declaration of Conformity (Example)
 3. Safety
 4. Technical Specifications
 5. Description and Operation
 6. Installation, Commissioning and Operation
 7. Maintenance and Inspection
 8. Troubleshooting
 9. Annexes
-



TECHNICAL MANUAL

Rotary Vanes | R/RFL G | P/PFL

1. General

INDEX

- 1.1. Introduction
 - 1.2. Copyright
 - 1.3. Machine Identification Nameplate
 - 1.4. Aftersales Service
 - 1.5. Warranty Conditions and Responsibility
 - 1.6. Personnel Training
 - 1.7. Using this Manual
-

TECHNICAL MANUAL

Rotary Vanes | R/RFL G | P/PFL

1. General

1.1. Introduction

This manual is related to the following machine: COMPRESSORS/VACUUM PUMPS Rotary Vanes R/RFL G a P/PFL, manufactured by MAPNER, S.A.

Business name: **MAQUINAS PNEUMATICAS ROTATIVAS XXI, S.L.U.** CIF: **B-75139675**

Address: **Polígono Industrial Zamoka Oialume Bidea 21 20115 Astigarraga Guipúzcoa España**

This manual has been developed to warranty that personnel who are going to work with the machine have the complete instructions for using it correctly and preserving it.

Therefore, this manual is intended for users and those responsible for the maintenance of the machine.

This copy is only valid for the machine which has been delivered with.

This manual is composed of 10 chapters in which the reader will find an overview of the machine, operating instructions and details of its components.

It features a chapter on Safety which contains all the rules to follow and warnings to keep in mind during assembly, transport and commissioning of the machine, along with a description of its security systems that work during operation.

Also, the manual shows detailed instructions for the emplacement, operation and maintenance of the machine, providing the operator and maintenance service with extensive information.

Lists of spare parts are included, indicating location and reference.

It is essential to keep in mind the information contained in this manual and to follow the instructions indicated prior the start-up and use of the machine, in order to guarantee the safety of both the machine itself and the operator, and to achieve an optimal performance.

TECHNICAL MANUAL

Rotary Vanes | R/RFL G | P/PFL

1. General

1.2. Copyright

This manual is property of:

MÁQUINAS PNEUMATICAS ROTATIVAS S.A.

This manual is intended for the exclusive use of its customers or distributors and should not be transmitted to third parties without permission.

It is strictly prohibited to

- Reproduce
- Disseminate
- Divulge

Any of the documents included in this manual either in part or in their entirety, without the prior authorization from this company.

Due to continuous improvement and after a constant search for innovation and technological quality, this "technical Manual" is subject to revision. The latest version is available on the website

www.mapner.com.

1.3. Machine Identification Nameplate



CAUTION

The machine nameplate identification sticker must be attached to the first page, behind the cover of this manual.

1.4. Aftersales Service

In case of this Manual has not enough information to solve problems, there is available for the client an Aftersales Technical Service, and all the special advice needed.

MAQUINAS PNEUMATICAS ROTATIVAS XXI, S.L.U.

Tel. +34 943 335 100 - Fax +34 943 335 480

Polígono Industrial Zamoka - Oialume Bidea 21. 20115, Gipuzkoa. España, Europa

Correo Electrónico: soporte@mapner.com Web: www.mapner.com

TECHNICAL MANUAL

Rotary Vanes | R/RFL G | P/PFL

1. General

1.5. Warranty Conditions and Responsibility

MAPNER rotary piston blower machines are only delivered after rigorous operating tests and verification of their components. However, the manufacturer declines all responsibility and removes all guarantee rights for machines operating in inadequate service conditions or which have been dismantled without prior authorization.

1. The machines are warranted for a period of 12 months from the date of shipment.
2. The warranty covers those parts of the machines which are defective either in materials, construction or workmanship. The warranty does not cover wearing parts (e.g. bearings), defects arising from corrosion or lubrication problems, from failure to follow the instructions contained in this manual, or from modifications or repairs not expressly authorized by MAPNER.
3. Any claims for defects must be made in writing and the purchaser is not entitled to withhold or delay any payments or cancel any contract as a result of these defects.
4. The supplier will not assume any responsibility under the terms of this warranty for equipment which have not been paid for at the time of the complaint.
5. Within the warranty period the supplier will repair or replace, ex works his factory, as soon as possible, those parts which are determined by him to be defective.
6. During the warranty period, faulty parts or machines must be returned to the supplier, carriage paid, and any part or machine repaired or replaced by the supplier will be returned to the purchaser, carriage to pay.
7. Repairs will be carried out in the supplier's workshop, and the supplier is not therefore liable for the costs arising from the removal or re-installation of the equipment (dismantling, packing, shipment, customs, assembly, etc.) or for any damage caused to other equipment or processes.
8. Any repair or replacement of a faulty part of the equipment supplied shall not affect the start date of the warranty on the equipment as a whole.
9. Where, for reasons of urgency, the supplier has to send a part of equipment for urgent replacement, the purchaser must send the faulty part of equipment for inspection within 7 days after the new part of equipment being dispatched. In case of failure to return the defective element, the new one sent as replacement will be invoiced.
10. Within the warranty period, for any product repaired or replaced by others than MAPNER or his representative, the warranty will become void and unenforceable and MAPNER shall not be liable for any type of damage that could happen after any unauthorized repair or replacement.
11. MAPNER shall not be liable for any damage directly or indirectly arising in connection with the machine non-use during the repair under guarantee. MAPNER shall not be liable for any damage directly or indirectly arising in connection with the incorrect use of the machines.
12. Any repair or manipulation in ATEX equipment by personnel not authorised by MAPNER will result in the loss of ATEX Certification of the machine, and eliminates the responsibility of the manufacturer in case of an incident.

TECHNICAL MANUAL

Rotary Vanes | R/RFL G | P/PFL

1. General

1.6. Personnel Training

The machine operator and the maintenance personnel must have a complete knowledge of its operation. In addition, the staff should be able to properly perform maintenance on the machine, in order to extend its life and increase the productivity by avoiding unnecessary stops.

Maintenance personnel of the machine must have accurate knowledge of mechanics, pneumatics, electricity, etc. to develop the maintenance and repair works. To this end, this staff must study the plans, schemes and documentation supplied with the machine, and what is indicated in this manual. The staff must also learn about the operation of the whole machine unit.

TECHNICAL MANUAL

Rotary Vanes | R/RFL G | P/PFL

1. General

1.7. Using this Manual

1.7.1. Abbreviations

1.7.2. Warning and Safety Indications

1.7.3. Illustrations

This manual, along its 10 chapters provides the information necessary for the maintenance of the **R/RFL/RS/P/PFL rotary vane compressor/pump**.

Every page contains, in its header and footer, the information related to the machine type, chapter number, revision number and page number

1.7.1. Abbreviations

R - Rotary Vane compressor, water cooled.

P - Rotary Vane pump, water cooled.

RFL - Rotary Vane compressor, air cooled.

PFL - Rotary Vane pump, air cooled.

AV - Side of the compressor where the transmission is located

AR - Rear side of the compressor

1.7.2. Warning and Safety Indications ▲

All the indications in this manual that are accompanied by the following symbols are intended to emphasize important and relevant instructions with regard to safety of the machine, the operator or even the environment.

The definition of the above indications is:



WARNING

If this warning is not observed or the instructions it contains are not followed correctly serious, even fatal, personal injury could be caused.



CAUTION

If this indication is not observed, or if the instructions featured therein are not correctly performed, machine components could suffer damage and/or destruction.

TECHNICAL MANUAL

Rotary Vanes | R/RFL G | P/PFL

1. General



ENVIRONMENT

Description of procedures and features in which it is advised to consider the possible environment implications of certain actions or elections, mainly in the usage of products.



NOTE

This is information / an indication with which it is recommended to comply.

1.7.3. Illustrations

Throughout the manual, certain descriptions and lists are accompanied by illustrations or photographs of machine parts, and by diagrams.

The drawings and diagrams of components and groups in this manual may be shown partially without their dimensions and in a simplified format. They are merely of an informative nature and have no contractual validity.

TECHNICAL MANUAL

Rotary Vanes | R/RFL G | P/PFL

2. EC Declaration of Conformity (Example)

-----, as the representative duly empowered to sign this declaration on behalf of MÁQUINAS PNEUMÁTICAS ROTATIVAS XXI, S.L.U., with registered office at Oialume Bidea 21, E-20115, Astigarraga (Guipúzcoa), Spain, **DECLARES THAT:**

The equipment to which this declaration relates complies with all the applicable provisions of the Machinery Directive 2006/42/EC of the European Parliament and the Council of 17 May 2006, as well as with the provisions of the Technical Construction File compiled for this purpose. The following are this equipment identification data:

	BRAND	: MAPNER
	MODEL	:
	Serial No(s)	:
	Construction year	:

The Technical Construction File was compiled by Mr-----, the duly authorised person to do so and established at Polígono Industrial Zamoka - Oialume Bidea 21, E-20115, Astigarraga (Guipúzcoa), Spain.

The equipment also conforms to the following community directives and/or relevant regulations:

- o Electromagnetic Compatibility Directive 2014/30/EU.
- o Low voltage Directive 2014/35/EU.

MÁQUINAS PNEUMÁTICAS ROTATIVAS XXI, S.L.U.

Oialume Bidea, 21 -Polígono Industrial ZAMOKA - Teléfono +34 943 335 100 - Fax +34 943 335 480 -
20115 ASTIGARRAGA (GUIPUZCOA). SPAIN

N.I.F. - IVA - ESA - 20024568

www.mapner.com

E-mail: mapner.info@mapner.com

TECHNICAL MANUAL

Rotary Vanes | R/RFL G | P/PFL



3. Safety

INDEX

- 3.1. Safety Instructions
 - 3.2. Equipment for Personal Safety
 - 3.3. Personnel Training
 - 3.4. Safety with Consumables
-

3. Safety

3.1. Safety Instructions

3.1.1. General Safety Instructions

3.1.2. Safety Instructions for Machine Operation

3.1.3. Additional Instructions

Every MAPNER machine has been manufactured in accordance with safety standards in design, manufacture and installation to avoid accidents during operation; however caution should be taken and some safety instructions should be observed.

These instructions should be used to supplement the accident prevention regulations applicable in each country or in the workshop.

3.1.1. General Safety Instructions

In conjunction with this instruction manual, general binding regulations should be observed and taken into account, as well as legal regulations and other measures to prevent accidents and to protect the environment.



WARNING

READ THE SERVICE INSTRUCTIONS MANUAL CAREFULLY BEFORE COMMISSIONING THE EQUIPMENT.

MANUFACTURER INSTRUCTIONS AND PREVENTION & SAFETY REGULATIONS INDICATED IN THE CURRENT LEGISLATION MUST BE STRICTLY FULFILLED.



WARNING

COMMISSIONING, HANDLING AND MAINTENANCE OF THE MACHINE MUST ONLY BE CARRIED OUT BY QUALIFIED PERSONNEL WITH EXPERIENCE OF BLOWER EQUIPMENT AND COMPONENTS.



WARNING

MACHINE ELEVATING OPERATIONS MUST BE CARRIED OUT ACCORDING TO THE APPLICABLE NATIONAL LAWS AND REGULATIONS.

3. Safety

3.1.2. Safety Instructions for Machine Operation



WARNING

THE USER MUST ENSURE THAT PERSONNEL WORKING WITH THE MACHINE COMPLIES WITH THE RULES AND DO NOT USE ANY WORK MODALITY THAT AFFECTS TO SAFETY.



WARNING

THIS BLOWER MACHINE COMPLIES WITH EUROPEAN SAFETY STANDARDS. BECAUSE ACCIDENT RISKS EXIST, PLEASE FOLLOW THE FOLLOWING SAFETY WARNING INSTRUCTIONS SCRUPULOUSLY:

- Keep the body and clothing away from rotating elements, as well as from suction and discharge orifices.
- Ensure that the unit is correctly earthed.
- Before commissioning blower equipment fitted with a soundproofed cabin, completely close all panels or doors, as applicable. The cabin may only be opened when the equipment has been completely switched off and the start-up system locked against accidental connection.
- Do not let unauthorized or unqualified personnel make unacceptable modifications or repairs to the blower equipment (ref. point 1.6).
- On completion of any handling and servicing operations, before the start up, re-install all the protection and safety features originally supplied with the equipment. Additionally check the correct closing of the soundproofing cabin, if applicable.
- Service conditions must be kept within project operating parameters.
- Never work with the compressor/pump out of the limits of the foreseen service conditions
- Ensure that all safety and control elements are correctly assembled and connected.
- Safety and protection devices cannot be removed when the machine is in operation.
- Instruction and Safety Manuals of the accessories supplied with the compressor/pump must be considered and respected.
- Before carrying out any operation using the equipment, stop the machine and disconnect the motor from the electric power supply. The equipment should also be isolated from the rest of the installation by means of the isolating valves.
- The cleaning and degreasing of the machine must be carried out once the machine is totally cold and with non toxic liquids or mixtures. Some of these fluids could react violently with high temperatures.
- The soundproofing cabin also acts as protection element, never open it while the machine is working, or allow unauthorized personnel access to the opening tools.

3. Safety

- Do not start the machine up with the inlet and discharge orifices open, as danger can be created in the surrounding area.
- In case that the supply solely includes the bare shaft, this manual includes the risks from the moment of its assembly in the rest of the group. It should be taken into account the trapping risks when manipulating the bare shaft during assembly operations.
- When making the assembly of the equipment together with other machines to build a new machine or a joint of machines that work as a unit, its control category must be respected according to the risk evaluation of the group.
- In any case the control system should be at least category PL c s/EN ISO 13849-1 and the access to possible trapping points should be prevented by the use of security devices according to that category.
- The Emergency Stop system must be category 0 s/EN 60204-1, unless the equipment final design could justify a different category. To complete this information consult the instructions of the electric supplier or installer.
- If the installation of a frequency converter is required, it must be communicated before the purchase of the electric motor.
- Do not modify any part of the machine, any of its working conditions and always use spare parts or materials supplied by MAPNER.

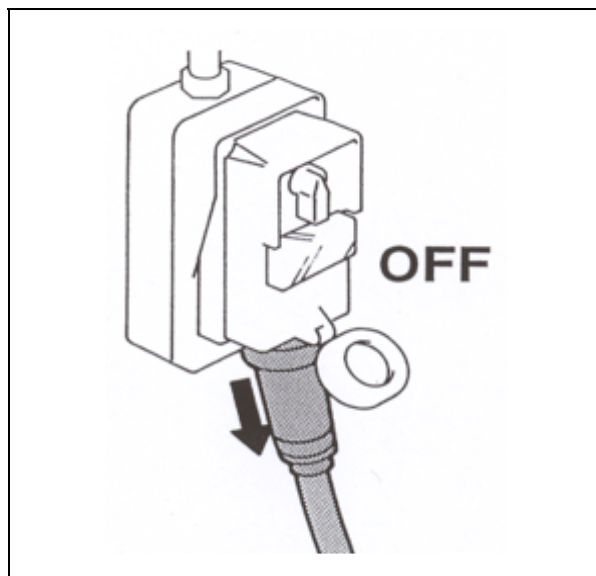

Figure 1. Electric Motor Connection.

3. Safety

3.1.3. Additional Instructions

In compliance with the Directive 94/9/EC (Potentially Explosive Atmospheres), additional safety instructions are indicated to complete the general safety recommendations contained in the manual.



Figure 2. ATEX Certification and Potentially Explosive Atmosphere Indications.
WARNING



WARNING

READ VERY CAREFULLY NEXT WARNINGS:

- The equipment working in ATEX conditions must fulfil the characteristics included in the certification dossier in custody by LABORATORIO OFICIAL J.M. MANDARIAGA.
- ATEX certified equipment cannot conduct, in any case, potentially explosive atmospheres, whether they are caused by gas or by dust. (There is no explosive atmosphere, if there is not a mixture of an inflammable gas with Oxygen).
- The equipment is designed to be used in a surrounding explosive ATEX atmosphere, but is not designed to carry an explosive atmosphere inside it.
- Check and make sure the Ex classification of the machine working area is consistent with the category of the compressor unit as stated on the relevant declaration or certificate. The end user has to define the ATEX classification area when placing the order.
- Do not use the machine without checking the correct sealing of the elements and the correct conduction of the fluids, to avoid mixture of flammable gases and air, or other dangerous mixtures.
- Before undertaking any work on or disassembly of the blower and ancillary equipment that make up the unit, allow it to cool down and to release all gas build-up from the circuit, and be alert to the possible formation of gas pockets. Equipment disassembling must be done by MAPNER's technical personnel.
- Any repair or manipulation in ATEX equipment by personnel not authorised by MAPNER will result in the loss of ATEX Certification of the machine, and eliminates the responsibility of the manufacturer in case of an incident.

3. Safety

- To avoid damaging the gaskets present in the blower unit, do not use aggressive products to clean the different components.
- Always use a temperature switch to limit the maximum operating temperature, see technical file of the equipment or contact MAPNER.
- The equipment could generate hot points, so it should always be used with adequate thermal control, automatic shut-off should be programmed in case of temperature rise. The temperature control must comply with the ATEX II b1 s / EN 13463-6 requirements as a minimum to ensure control of the ignition source. Check the correct regulation of the thermal control with respect to the required thermal class.
- Before initial start-up, after prolonged shutdown, failure or after maintenance of ATEX equipment, the operation of inertization the interior of the equipment and its accessories must be carried out prior to the start up of the machine.



CAUTION

Read carefully next security cautions.

- If you need to replace any parts of the machine, always use MAPNER original spares.
- Avoid installing the blower unit in premises prone to dust concentration, where dust may pile up on the machine.
- Check the inlet filter for good working condition, cleanness, and correct installation.
- Under no circumstances shall the original operating parameters of the blower (inlet temperature, fluid composition, differential pressure, blower speed, etc.) be changed without MAPNER's previous approval in writing.
- Test the pressure control valve and the safety elements (Thermostat, Pressure...) switch to verify that they work properly.
- Check and suppress all stress and/or overload that the pipes connected to the inlet and discharge flanges may transmit to the blower unit.
- Make sure the electric drive motors and the control and safety devices meet the requirements for the specified category of equipment with regard to the classification of the working area.
- For ATEX machines, due to safety reasons, always original spare parts supplied by MAPNER must be used.

3. Safety

3.2. Equipment for Personal Safety

Maintenance personnel must use suitable clothing to avoid accidents. In particular, do not use ties, rings or chains that could get caught in moving parts of the machine. Long hair should be properly collected.

Avoid wearing loose garments when close to the machine in operation..



WARNING

THE SURFACE OF THE BLOWER CORE AND ELEMENTS LOCATED IN THE FLUID FLOW CAN REACH TEMPERATURES ABOVE 70°C. AFTER STOPPING THE MACHINE, WAIT UNTIL THEY HAVE COOLED DOWN.



WARNING

WHEN WORKING NEAR THE MACHINE, ESPECIALLY IN THE ABSENCE OF A SOUNDPROOFED CABIN, EAR PROTECTORS MUST BE USED.

When working near the machine, it must be considered that the Standard MAPNER equipment in normal working conditions overpass the acoustic pressure of 70 dB(A), and in some demanding conditions this value could reach the 110 dB (A) or even higher values. The mentioned valued must be taken into account together with the applicable legislation in order to select the necessary prevention and security actions for the personal that could be exposed to this sound level.

The concrete real sound level value for each machine will be included in its technical offer. (*Acoustic Pressure Value, according ISO 2151:2004 \pm 2dB(A))

NOTE: Reference legislation: Directive 2003/10/EC of the European Parliament and of the Council of 6 February 2003 on the minimum health and safety requirements regarding the exposure of workers to the risks arising from physical agents (noise)

MAPNER is able to offer soundproofing elements to be installed together with the machine with the objective to reduce the produced sound level.

Indirect sources of noise that may exist in the facility and that could amplify the noise generated by the blower / depressants should also be taken into account.

3. Safety

In order to carry out the maintenance tasks safely, the equipment included in the risk assessment of the customer's plant must be used, as basic recommendation the following clothing could be indicated:



EQUIPMENT	UTILIZATION
Footwear 	Must be safety shoes with reinforced toe. If not used properly can result in feet crushing.
Gloves 	Must be suitable for every type of work, such as work with sharp-edged items. Do not use gloves under warning of snagging.
Helmet 	For works in which there is warning of head injuries, especially in assemblies or disassemblies, and in movement of heavy elements by means of a crane.
Workwear 	For every work, the most appropriate clothing must be worn, avoiding garments that can generate a warning, such as snagging on mobile elements, being flammable, being uncomfortable to perform the required tasks, etc.
Ear protection 	Earplugs or safety headphones can be used against the noise from the machine or its maintenance tasks.

Table 1. Equipment for Personal Safety

3.3. Personnel Training

Only trained personnel should be employed and trained both in usage and in maintenance of the machine.

The responsibilities of the staff for installation, operation, and maintenance of the machine must be set out clearly. Thus, it must also be ensured that only the staff trained for each purpose can act on the machine.

Maintenance personnel of the machine must have accurate knowledge of mechanics, pneumatics, electricity, etc. to develop the maintenance and repair works. In addition, they must first be trained in the operation of the machine, its different parts and regular maintenance and common faults. This staff must study the plans, schemes and documentation supplied with the machine, and what is indicated in this manual.

A machine responsible must be designated, even for legal requirements, and he must have the capability to deny actions that compromise safety to third parties.

3. Safety

3.4. Safety with Consumables

3.4.1. Used Oils

3.4.2. End of the Equipment Service life

Oils, greases, fluids and other chemicals used in the machine must meet legal regulations for environmental protection.



ENVIRONMENT

Produced waste can lead to environmental problems and must be managed correctly in accordance to local regulations.

3.4.1. Used Oils

Any industrial oil or lubricating substance, with mineral or synthetic base, is considered used oil when it has become unusable for its initial purpose.



ENVIRONMENT

Always store used oil in good condition, avoiding mixing with other waste, as well as with water or other oily waste.



ENVIRONMENT

Used oil must be stored in facilities that enable good and safety conservation until collection by the appropriate authorized agent.

3.4.2. End of the Equipment Service life



ENVIRONMENT

Once the equipment reaches the end of its service life it must be removed and managed in accordance with the valid legislation of the country where the withdrawal is made.

TECHNICAL MANUAL

Rotary Vanes | R/RFL G | P/PFL



4. Technical Specifications

INDEX

4.1. Machine Identification

4.2. Machine Technical Specifications

TECHNICAL MANUAL

Rotary Vanes | R/RFL G | P/PFL

4. Technical Specifications

4.1. Identificación de la Máquina



CAUTION

For any correspondence, please always refer to the type and the machine Serial Number which are located on the Nameplate, or in label in section of this Manual.

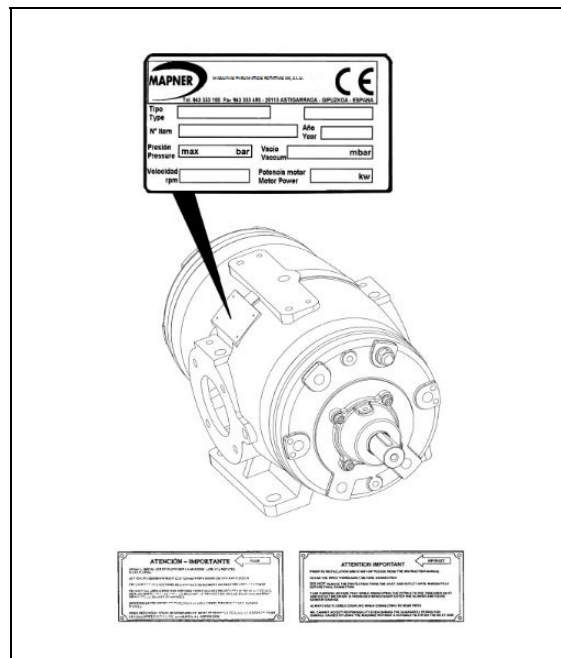

CAUTION

The Nameplate and warning plates on the machine must never be removed. If the Nameplate is damaged or illegible, please ask MAPNER for replacement.

Take note of the Number and Type of the machine and keep Technical Manual with the rest of installation documents.

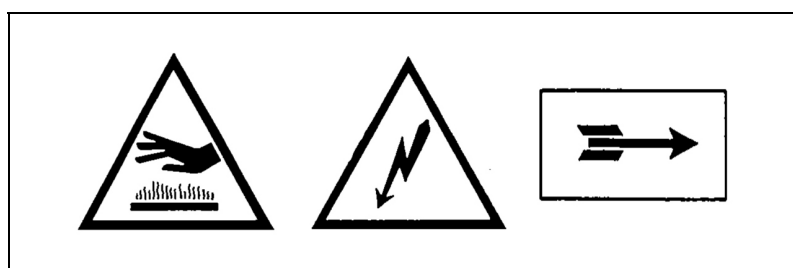

TECHNICAL MANUAL

Rotary Vanes | R/RFL G | P/PFL



4. Technical Specifications

4.2. Machine Technical Specifications

TYPE	R/RFL/P/PFL (Rotary Vane Compressor/Pump)
Operations:	Suction and discharge of gaseous fluids
Suction pressure:	(see machine nameplate)
Discharge pressure:	(see machine nameplate)
Rotation speed:	(see machine nameplate)
Differential pressure:	(see machine nameplate)
Motor power:	(see machine nameplate)
Noise emission:	> 70 dB
Machine dimensions:	(see dimensions drawing)

TECHNICAL MANUAL

Rotary Vanes | R/RFL G | P/PFL



5. Description and Operation

INDEX

- 5.1. Machine description
 - 5.2. Cooling circuit
 - 5.3. Equipment
 - 5.4. Applications, Uses and Remaining Risks
-

TECHNICAL MANUAL

Rotary Vanes | R/RFL G | P/PFL

5. Description and Operation

5.1. Machine description

A rotary compressor consists of a cylindrical stator housing a rotating rotor mounted at both ends on a cover. This eccentrically fixed rotor has a number of slots that provide seating to the blades which run along the internal surface of the stator.

The blades form various chambers whose capacity increases from the inlet orifice onwards and then decreases progressively up to the discharge orifice.

As the rotor rotates, the blades move outwards due to the centrifugal force effect and touch the stator's internal surface. The blades slide on a thin oil film which ensures perfect tightness as well as the blades' balance and smallest possible friction.

The inlet orifices in the stator allow fluid to enter the chambers at the time their capacity increases. The stator's discharge orifices let fluid out when the chambers' capacity has decreased enough to compress gas to the required pressure. Each end of the rotor is protected by a special cover; the drive side cover contains a sealing gasket that adjusts any play automatically.

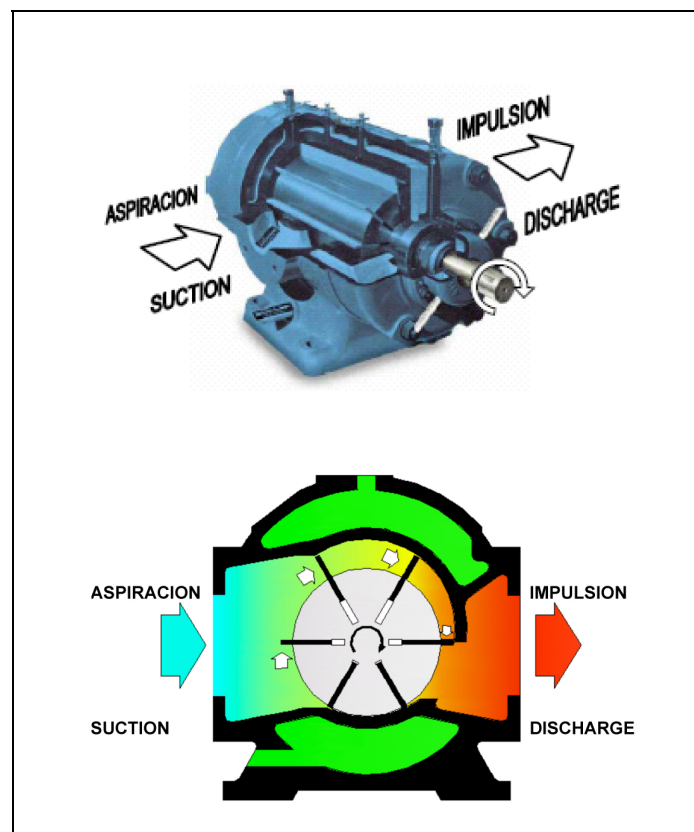

5. Description and Operation

5.2. Cooling circuit

Water intake lies at the lower part of the machine and outlet is at the top. The water supply line to the machine must be properly sized to ensure correct cooling of the machine.

It is desirable to install a three-way valve near the water intake. This valve would serve to control the water inflow and machine drain as and when necessary. If the units consist of several stages or coolers, there must be drip cocks at the different lower points.



CAUTION

Whenever there is a risk of frost, all water must be drained out of the machines and coolers, to prevent serious damage.

We strongly recommend that a solenoid valve be fitted at the water intake. In this event, water flow shall be controlled by means of a manual valve upstream of the solenoid valve (see figure).

Insofar as possible, prevent suspended solids that would settle in the chambers from entering the system. Should cooling water leave residues in the cooling chambers, they should be swept periodically by introducing compressed air into the water circuit.

It is recommended to use water circuit monitoring and safety systems that would stop the machine immediately if coolant failed.

For greater safety's sake, the water outlet should be coupled to a funnel allowing visual check.

Closed cooling circuits must be equipped with monitoring systems that establish correct circulation of water.

The water outlet temperature shall not exceed the specified limits (42°C maximum). A thermometer must be mounted to measure this temperature. The maximal pressure of the water would be 3 bar.

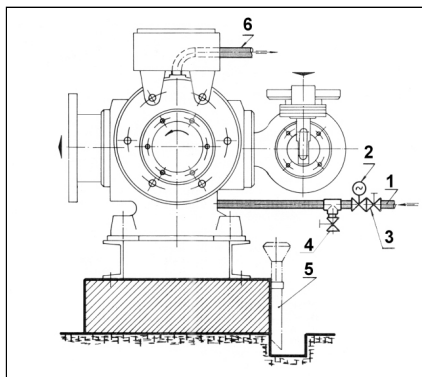

1. Water intake
2. Solenoid valve (opt.)
3. Check valve
4. Drain cock
5. Exhaust manifold
6. Water outlet

5. Description and Operation

REMARK:

Pressure contact-controlled compressors or vacuum pumps subjected to frequent restarts during a workday must obligatorily have a solenoid valve installed on the water circuit in order to cut the coolant supply at each stoppage of the machine.

The reason for taking this precaution is that: if coolant continues circulating through the cooling chambers, the stator will quickly attain the water temperature and shrink. By contrast, the rotor, which is not in contact with the coolant, remains at high temperature. At times, there can be no clearance between the rotor and the rear cover and, in this event, the two parts would touch each other, causing seizure at the next restart.

Also, that portion of the rotor tangent to the stator bore tends to cool down faster than the diametrically opposed portion, which creates upwards bending. At the next restart, 'eccentricity seizing' could occur, i.e. seizure between rotor and the stator eccentricity.

On the contrary, if there is no coolant flowing through during the machine stoppage, the stator warms up and expands. The play between the rotor and rear cover increases, preventing seizure at the next restart. Anyhow, it is highly recommended, not to say indispensable in certain cases, to install a solenoid valve in order to avoid accidents due to total absence of or insufficient coolant.

TECHNICAL MANUAL

Rotary Vanes | R/RFL G | P/PFL

5. Description and Operation

5.3. Equipment

- 5.3.1. Non return valve
- 5.3.2. Safety valve
- 5.3.3. Aspiration filter
- 5.3.4. Coolers
- 5.3.5. Elementos de control y seguridad
- 5.3.6. Cabina insonorizante
- 5.3.7. Sistema de Limpieza
- 5.3.8. Otros elementos accesorios (opcionales)

5.3.1. Non return valve

DESCRIPTION

The check valve is designed to prevent fluid and borne materials from flowing back into the machine in the event of any possible stoppage. In addition, it avoids the back pressure building in the lead line to cause the machine to rotate contrariwise

CP-B SERIES

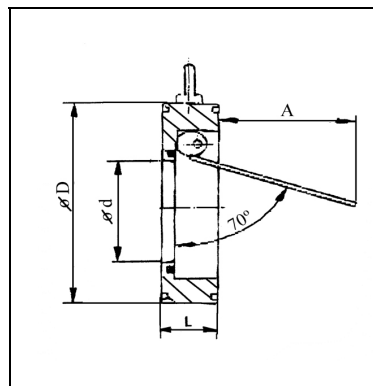

DN	50	80	100	125	150	200	250	300	350
ØD	98	134	154	181	209	264	319	375	425
Ød	35	54	70	92	114	152	192	230	266
L	24	27	29	34	34	41	48	57	69
A	32	50	152	93	111	140	174	205	232

ASSEMBLY SCHEME

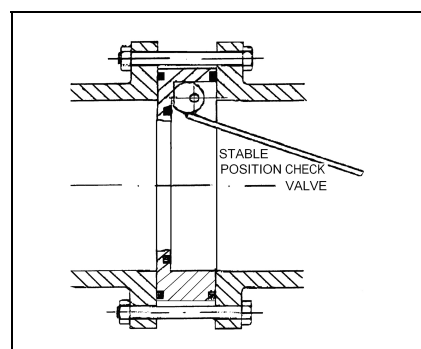

TECHNICAL MANUAL

Rotary Vanes | R/RFL G | P/PFL



5. Description and Operation

RUBER-CHECK SERIES. "C" Model

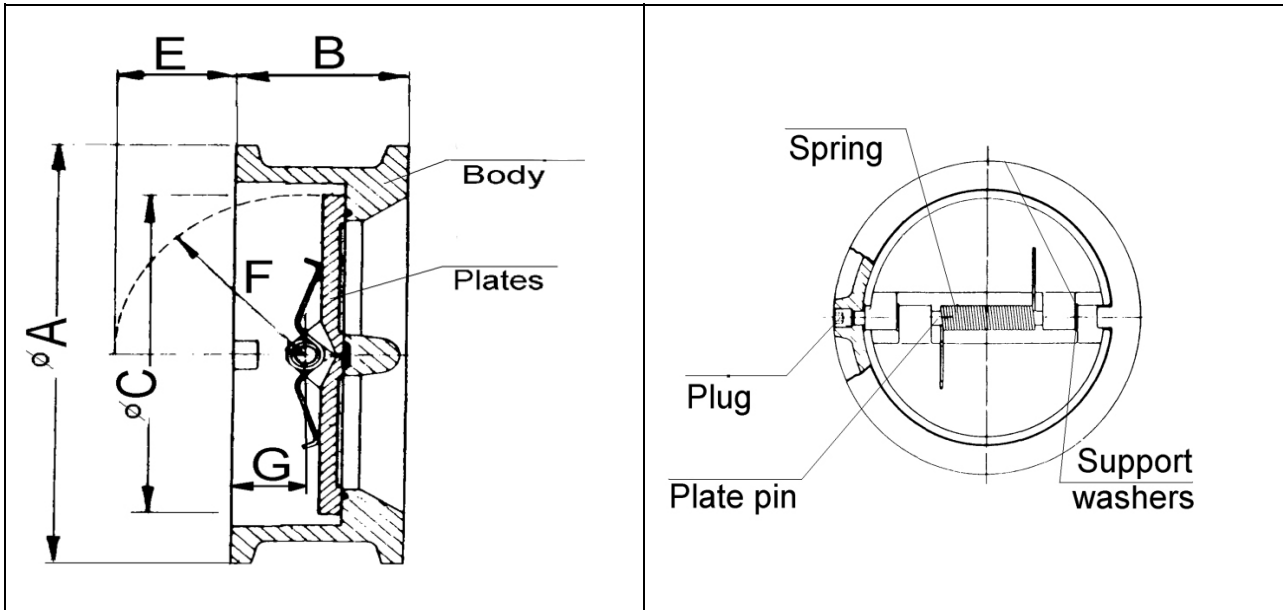

VALVE DN		A (mm)		
mm	"	PN 10/16	PN 25	ANSI 125
40	1 1/2	94	94	-
50	2	109	109	104
65	2 1/2	129	129	124
80	3	144	144	137
100	4	164	164	166
125	5	194	194	194
150	6	220	220	220
200	8	275	284	275
250	10	330	341	338
300	12	380	403	405
350	14	440	460	450
400	16	491	515	515

VALVE DN		mm				
mm	"	B	C	E	F	G
40	1 1/2	43(1)	58	18	33	18
50	2	43	58	12	33	12
65	2 1/2	46	58	12	33	12
80	3	64	71	18	41	18
100	4	64	96	28	52	28
125	5	70	125	35	70	35
150	6	76	128	33	70	33
200	8	89	192	60	104	60
250	10	114	244	81	126	81
300	12	114	295	100	153	100
350	14	127	320	108	168	108
400	16	140	380	137	195	137

5. Description and Operation

MAINTENANCE

According to maintenance table point 7.2, check that the closing of the valve is correct and joints must be replaced.

5.3.2. Safety valve

According to the equipment size, operating conditions and type of transported fluid, an adequate safety valve has to be installed to protect it from possible overloads.



CAUTION

This valve must not be used as a regulating device.

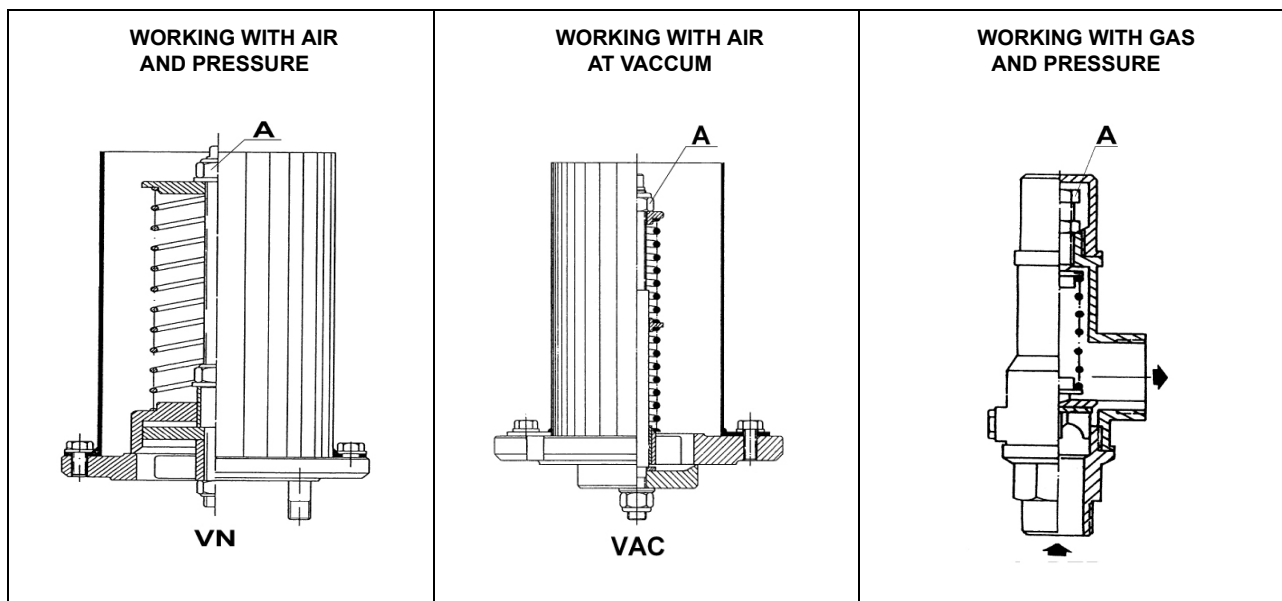

The safety valve is to be mounted in the fluid discharge line in such a way that there is no shutoff or isolating device between the machine and the valve inset point.

Sometimes, the safety valve can be supplied without mounting; you must clean the inset point area thoroughly and avoid stresses which may lead to the deformation of the valve components. These valves are supplied as factory-preset. However, we strongly recommend performing a final adjustment for the actual operating conditions after start-up.

If gas is the transported fluid, valves with piped exhaust, calibrated and sealed as a function of the required pressure. The exhausted gas must be piped to the admission as far as possible to avoid overheating, if no possible, it have to be refrigerated.

Vacuum equipments are protected by means of VAC vacuum-limiting valves.

5. Description and Operation

Readjusting or adapting the triggering value to the operating pressure is achieved by turning the regulating nut (A). Tighten the nut to increase the triggering pressure or loosen the nut to decrease the pressure.

The safety valve setting shall be 5% greater than the rated working pressure.

CAUTION



When calibrating the safety valve, do not introduce your fingers or other objects into the threads of the spring, since this can cause injury or impair the correct functioning of the valve.

Air exiting the valve can be very hot and cause physical damages.

Periodically check the safety valves for correct operation. The valves should never leak, if it does, it means that there is an issue that must be solved immediately.

5. Description and Operation

5.3.3. Aspiration Filter

5.3.3.1 FXG inlet separator filter

5.3.3.2 FIH Filters

5.3.3.1 FXG inlet separator filter

OPERATIONAL DESCRIPTION

This filter retains fluid (gas)-borne solid particles and coarse condensates at the inlet line to the compressor.

Filtering and separating stages:

- (a) A first area eliminates a high portion of the particles and emulsified residues which fall by gravity into the bottom of the separator filter.
- (b) The fluid flows through the filtering panel (7) and, once expanded, it flows through the filtering element (4) into the compressor. The condensates produced at this filtering stage also settle in the lower container.

PERMANENT DRAIN SYSTEM

Owing to the design of the separator, any liquid can be permanently drained out of the bottom of the container. To prevent fluid leakage and to maintain a pressurisation balance, do the following:

Close the valve (18) and through the vent tube (17) fill the container with the amount of water specified in the table. Next, open the valve (18) to keep the permanent draining system operative.

LOCATION

The inlet separator filter shall be fitted into the inlet line, preferably coupled direct to the compressor.

MAINTENANCE

- 1) Keep the drain valve (9) permanently open, after having adjusted the outflow for the quantity of condensate build-up.
- 2) Check the level of condensates.
Periodically inspect the filtering element (4) and change it as and when necessary. The frequency of this inspection depends only on the condition of the processed fluid-gas.
- 3) For safety's sake, you would be well-advised to change the O-ring (3) whenever observing the slightest sign of damage.

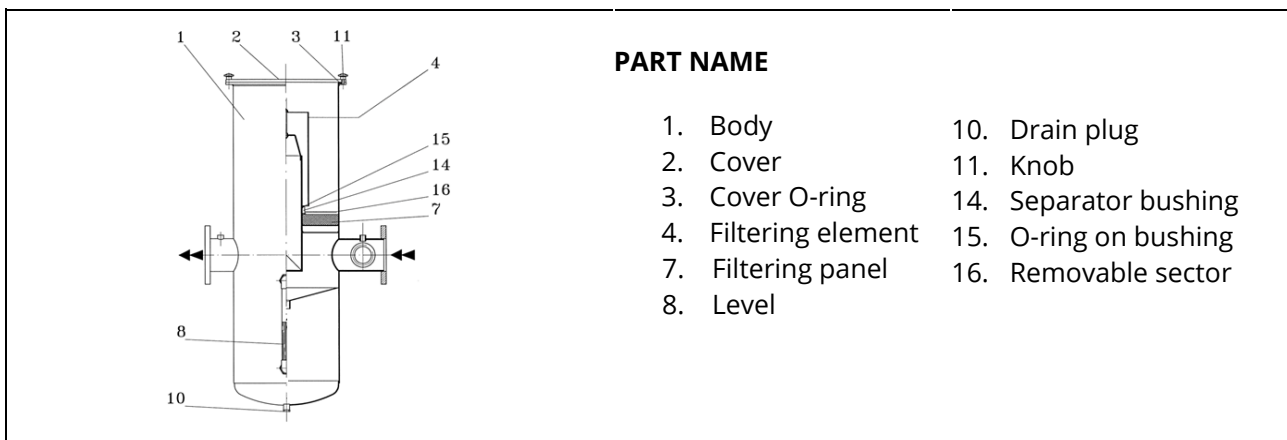

5. Description and Operation

5.3.3.2 FIH Filters

Compressor equipment that operates in zones not classified as ATEX with air, have an intake filter of the FIH type.

The combined silent filter incorporates a sound attenuation compartment as part of the unit.

Check the filter element periodically and clean or replace it whenever necessary.



Figura 43. Cleaning of the Filter

To extract the filter element (4), open the revolving shackles and disassemble the cover (1). The cleaning of the filtering element should be done with detergent and air at low pressure. If it is very clogged, it must be replaced.

Clean the inside of the filter body and check the condition of the sealing gasket (5).

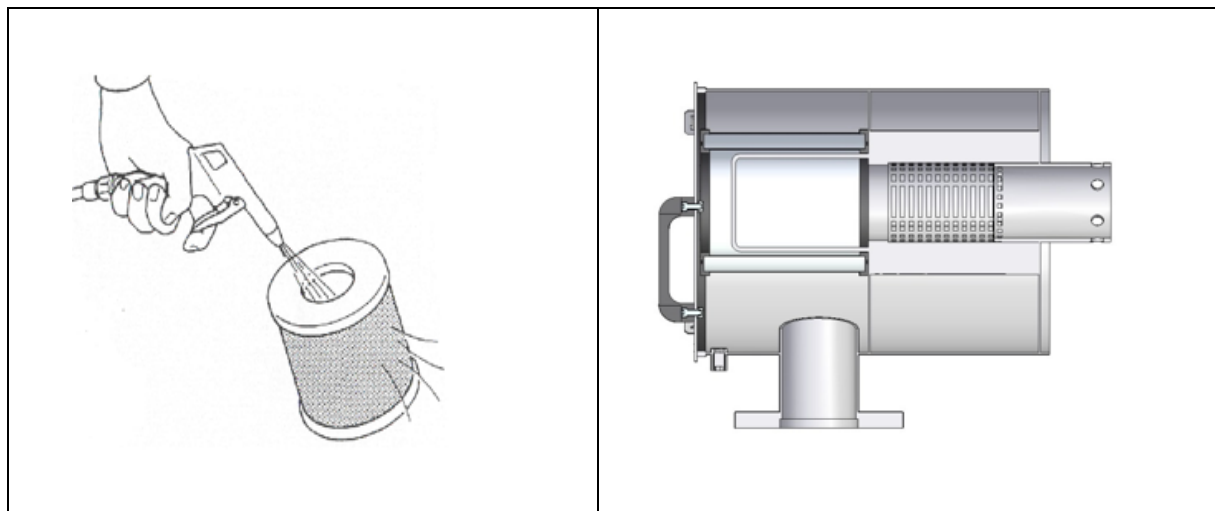

WARNING

Some elements may be ejected. Adequate personal protective equipment must be used.

TECHNICAL MANUAL

Rotary Vanes | R/RFL G | P/PFL

5. Description and Operation

5.3.4. Coolers

Heat exchanger made of removable bank tubes for easy periodical cleaning of the internal parts of the device, thus ensuring optimum performance.

Cooling water runs on the outside of the bank tubes counter to compressed air or gas stream inside the heat exchanger tubes.

The cooling system allows the temperature of the transported fluid flowing through it to decrease to an average value of 10°C above the cooling water temperature.

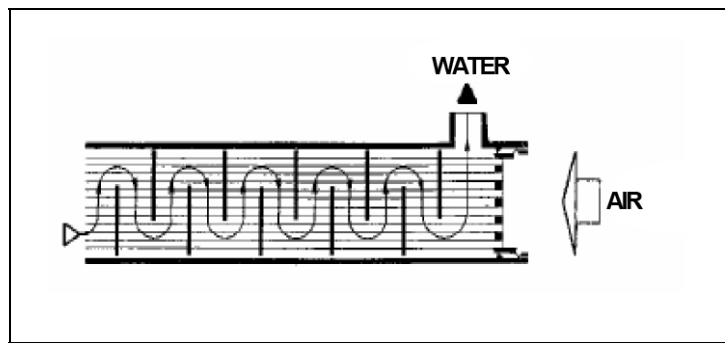

Installation

In general, the installation position of a cooler is horizontal; however, heat exchangers can be mounted vertically if specified at the order stage.

Liquefied condensates resulting from the transported fluid cooling process remain and condensate in the centrifugal separator that we can optionally couple to the outlet of the cooler.

To ease draining accumulated condensate from the separator tank, we recommend fitting an electromagnetic trap or a float-actuated mechanical system.

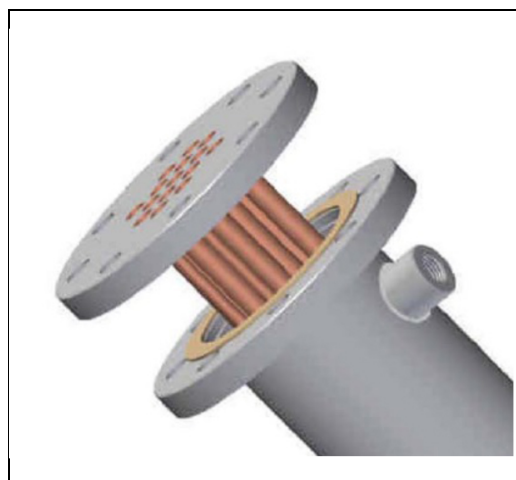

5. Description and Operation

5.3.5.- Control and safety elements

For safety reasons, the compressor unit is equipped with the following control elements:

- Pressure switch/Vacuum switch: regulated according to the design pressure/vacuum of the unit. It sends a signal to the plant control panel that causes a shutdown if the unit exceeds the set value.
- Thermostat: regulated for a safe operating temperature. If this value is exceeded, the thermostat sends a signal to the plant control panel that causes a shutdown of the machine.
- Oil level sensor: a switch located in the oil tank that sends a signal to the control panel to cause a shutdown of the machine if a very low level of lubricating oil is detected. Operating the equipment without oil can lead to a breakdown.
- Water flow switch: placed in the cooling water circuit to send a signal to the control panel if an insufficient level of cooling water is detected.

In the case of ATEX equipment, these elements are compulsory, to ensure the correct operation of the equipment within the design parameters.

5.3.6.- Soundproofing cabin

The modular soundproofing cabins are made of galvanized plate panels. Inside ventilation is provided by a self-contained motor-driven fan integrated into the cabin.

At the same time, the acoustic cabin serves to protect the belt and pulley drive system. Consequently, it is essential that the panels or doors of the soundproofing cabin should be totally closed.



CAUTION

The closing / locking of the panels should be performed with the supplied tool. Access to this key should be permitted only to authorized personnel.



5. Description and Operation



CAUTION

For any servicing of the compressor unit, stop the equipment completely before opening the panels or access doors of the cabin.

The exhauster fan will be switched over with the main drive motor. When a frequency converter is used, the speed regulation must not affect the exhauster fan motor.

To avoid overheating inside the cabin after stopping the compressor unit, the exhauster fan must be kept operating for 6 to 10 minutes by means of a timer.



CAUTION

Do not remove the safety instruction labels affixed to the outside of the cabin.

5.3.7 Cleaning System

Sometimes the suction fluid that drives the compressors or pumps is very dirty and corrosive. To mitigate - never avoid - this defect, a "cleaning system" has been created.

Corrosion in this type of environment generally appears during shutdowns, which is when corrosive products accumulate and cause the biggest problems.

The cleaning system consists of a tank where the anti-corrosion/cleaning product is introduced. This tank is linked to the suction device and impeller of the compressor core and is insulated via two valves.

When a machine shutdown is planned, and while the machine continues to operate, the two valves of the cleaning system are opened. At that moment, the container tank is pressurized and the fluid inside it is forced to enter the suction zone.

The fluid is sprayed, cleaning some of the remaining impurities and covering the interior metal surfaces, partially protecting them from direct corrosion.



CAUTION

The damage caused by the spread of oxidation in our equipment is not covered by our warranty.

5. Description and Operation

5.3.8. Other accessory elements (optional)

5.3.8.1. Outlet silencer

5.3.8.2. Cooling water closed circuit

5.3.8.3. Centrifugal separator

5.3.8.4. Condensate vent

5.3.8.1. Outlet silencer

Silencers could be mounted in the machine outlet to reduce noise levels. There are different types, depending on specific operating characteristics. They are specifically designed for operation with different gases from those that the blade equipment works with.

5.3.8.2. Cooling water closed circuit

In installations where obtaining water for equipment cooling is difficult, it is possible to install a closed circuit for cooling. This system usually consists of a water cooler, a pump for water circulation and an expansion tank. The cooling equipment is dimensioned according to the specific operational needs and characteristics of the location.

5.3.8.3. Centrifugal separator

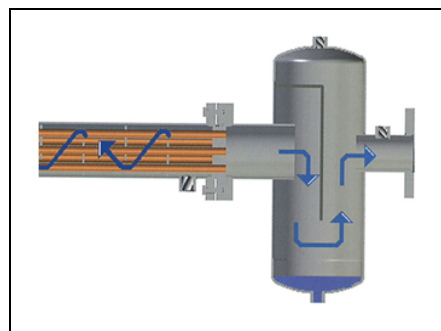

The MS centrifugal separator allows the retention and accumulation of liquefied condensates and solid particles contained in the compressed fluid that circulates through the piping.

The MS separator located in the compressed fluid network creates a continuous centrifugal action of the molecular mass of fluid, which creates turbulence and friction on the internal surface of the separator. The centrifugal effect and abrasion leads to the condensates adhering to the diametric walls of the separator system.

The force of gravity and the thrust of the gaseous mass moves the condensates to the bottom of the storage tank.

The condensates generated and accumulated at the bottom are then discharged outside through a manual or automatic bleeding system.

5. Description and Operation

5.3.8.4. Condensate vent

The automatic MAPNER PRG 1" (1) vent eliminates the condensate generated in equipment or installations that work with air or other compressed gases. The automatic bleeding through the vent is controlled by a float (3). Due to gravity, the flow of condensates descends as far as the bottom of the tank. As the level of fluid increases the float moves upwards, allowing the opening of the valve (2) through the branching of the float. When the level of condensate falls, the valve closes again.

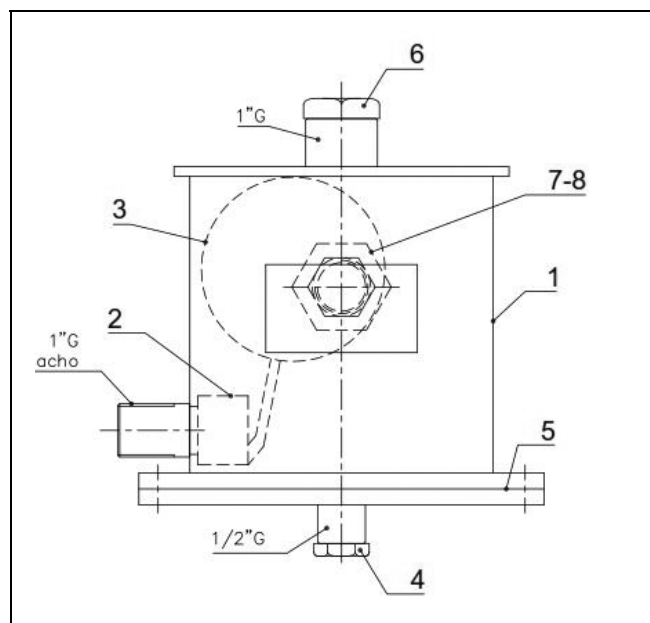

POS.	CODE	DESCRIPTION
		ZDPUR1M
1	ZDPUR1	DRAIN PRG 1"
2	ZVALFLO38	FLOATING VALVE 3/8"
3	ZBOYA110	FLOAT Ø110
4	ZTAP16	HEXAGONAL PLUG 1/2"
5	ZJUN2266	O-RING 202,8 X 3,53
6	ZTAP15	HEXAGONAL PLUG 1"
7	ZUNIONLMH1I	MALE FEMALE JOINT 1"
8	ZUNIONDM1I	DOBLE MAIL JOINT 1"

5. Description and Operation

5.4. Applications, Uses and Remaining Risks

5.4.1. Applications

5.4.2. Reasonably Foreseeable Incorrect Use

5.4.3. Residual Risks

5.4.1. Applications

The proposed uses of this machine are listed below:

- Industrias elaboradoras y manipuladoras de papel.
- Paper manufacturing and processing industries
- Pneumatic conveyors
- Packing and conveyor facilities
- Textile industry
- Smoke and fine dust removal
- Suction cap lifters
- Fish farming
- Sewage treatment plants
- Water treatment
- Agricultural machinery
- Aquarium oxygenation
- Tobacco processing
- Electric and electronic industry
- Bottling plants
- Agitation process in galvanic treatments
- Desalination plants
- Other non-described applications, ask MAPNER

5. Description and Operation

5.4.2. Reasonably Foreseeable Incorrect Use

The following Reasonably foreseeable incorrect uses must be avoided:

- Installation on uneven or irregular surfaces.
- Installation outdoors without the right protection.
- Installation in an enclosure without suitable ventilation.
- Operation without lubrication.
- Use the eyebolts located in the ceiling of the cabin to lift the complete unit.
- Non-compliance of the service data indicated on the plate.
- Non-compliance of maintenance intervals.
- Non-compliance with the maintenance operations indicated in section 7.
- Wrong turning direction.
- Connection of the machine during maintenance operations.
- Incorrect connection of the motor.
- Operation of the equipment at a pressure above the value indicated on the plate.
- Operation of the equipment at a different speed from the one indicated on the plate. (If you need to modify this speed, please consult MAPNER).
- Exceeding the upper limit temperature.
- Manipulation of any element of the machine while it is operating.
- Operating without the safety devices included in the unit.
- Removal of safety devices while the machine is operating.
- Operation without elements that prevent access to moving parts, rotor, pulleys...
- Operation ignoring the safety instructions indicated in section 3.

5.4.3. Residual Risks

Please note that in any case some residual risks may remain

- The compressor unit does not constitute a work station, so it may be a hazard to persons that are exposed to the noise of the machine for long periods of time.
- There may be vibrations.
- Risks may arise depending on the characteristics of the gas impelled.
- Possible tilting of the machine if its base is defective.
- Pressure/vacuum valve: possible risk of entrapment when it is operating.

6. Installation, Commissioning and Operation

INDEX

- 6.1. General Notes on Delivery
- 6.2. Transport and Handling
- 6.3. Storage
- 6.4. Sitting
- 6.5. Foundations and Fixings
- 6.6. Assembly
- 6.7. Alignment and Tensing of Pulleys and Belts
- 6.8. Flexible Coupling
- 6.9. Start-Up



WARNING

COMMISSIONING, HANDLING AND MAINTENANCE OF THE MACHINE MUST ONLY BE CARRIED OUT BY QUALIFIED PERSONNEL WITH EXPERIENCE OF BLOWER EQUIPMENT AND COMPONENTS.



WARNING

TO PERFORM COMMISSIONING, HANDLING AND MAINTENANCE OPERATIONS ALL THE INSTRUCTIONS AND SAFETY WARNINGS INCLUDED ON CHAPTER 3 SECURITY MUST BE CONSIDERED.



WARNING

BEFORE INITIAL START-UP, AFTER A PROLONGED SHUTDOWN, FAILURE OR AFTER MAINTENANCE OF ATEX EQUIPMENT, THE OPERATION OF INERTIZATION OF THE INNER PART OF THE EQUIPMENT AND ITS ACCESSORIES MUST BE CARRIED OUT PRIOR TO STARTING UP THE MACHINE.

TECHNICAL MANUAL

Rotary Vanes | R/RFL G | P/PFL

6. Installation, Commissioning and Operation

6.1. General Notes on Delivery



CAUTION

Avoid impacts and accidental fall when handling the machine either packed or unpacked.

Immediately upon receipt, please check that:

- A) The packing is not damaged.
- B) The goods supplied correspond to order specifications (check the delivery note):
 - 1- Compressor group
 - 2- Instruction manual (if it comes)
 - 3- Optional accessories:
 - Suction filter for blowers
 - In-line filter for exhausters
 - Non return valve
 - Etc



CAUTION

MAPNER would no accept any responsibility for defects due to transport or lack of material not notified in writing during the 24 hours upon receipt.

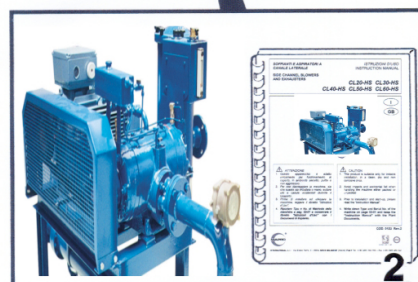

6. Installation, Commissioning and Operation

6.2. Transport and Handling

- During transport and handling of the equipment, special attention must be paid to protecting it against any blows that could affect the machine.

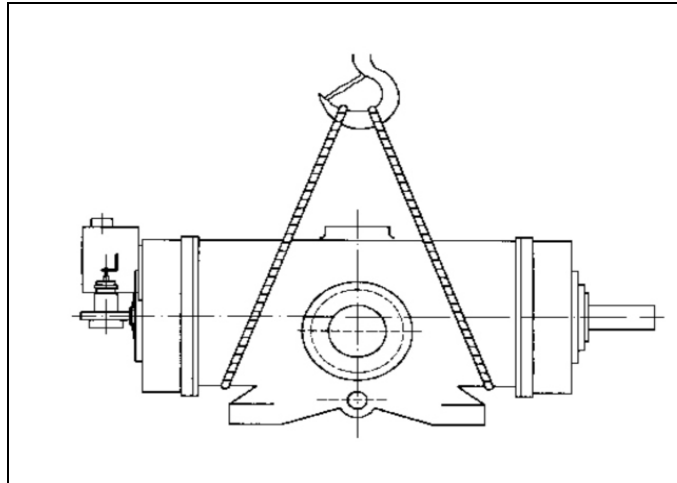

- Transport the equipment by crane, forklift truck or similar means.
- For lifting the unit without its cabin, refer to the enclosed pictures and use only steel ropes or polyester slings in perfect condition and approved for this application and weight.



CAUTION

If by the use of the slings or chains, the load could be damaged a suspension beam or similar element must be used.

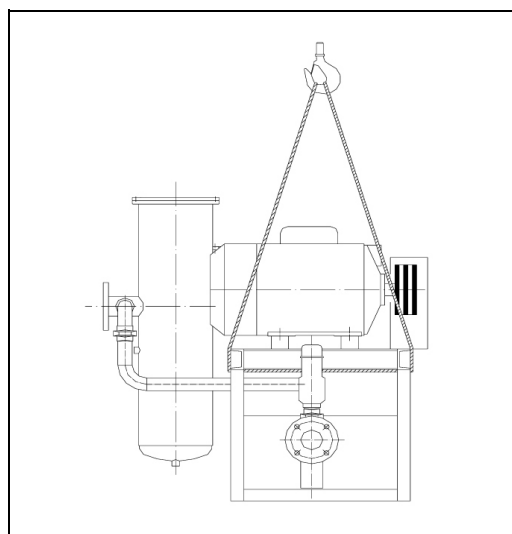

6. Installation, Commissioning and Operation

- The rotary compressor or vacuum pump group with sound-proofed cabin should be transported on a pallet truck

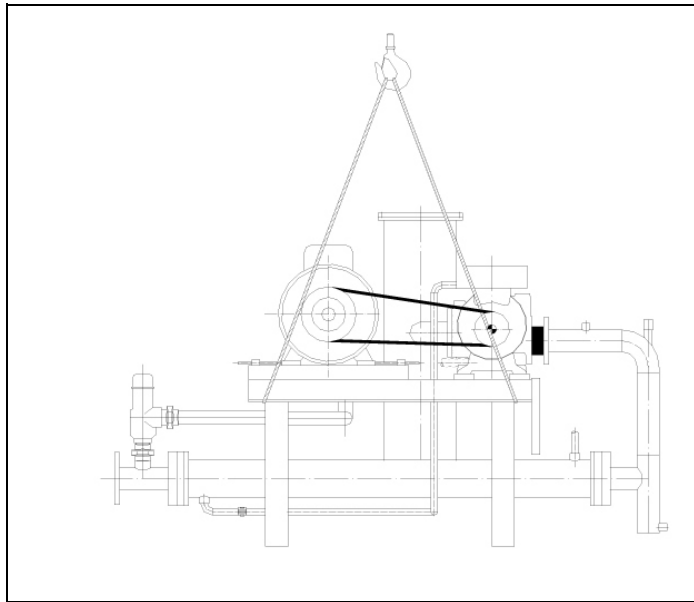

CAUTION

The eyebolts on the cabin roof are only to be used for handling said cabin. Do not use them to lift the unit.

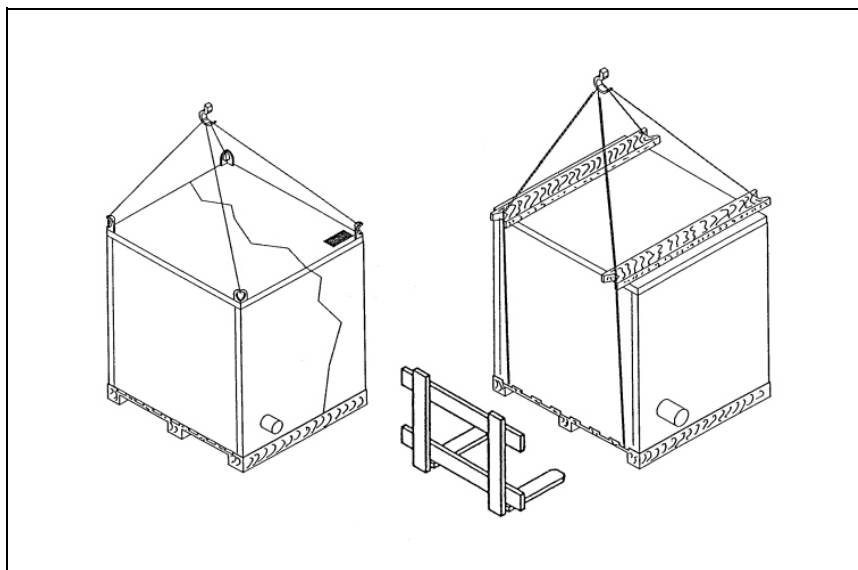

6. Installation, Commissioning and Operation

6.3. Storage

- a) The conditions of the storage premises or working site are essential to keep the equipment in optimum operating conditions.
Our machines should be stored or installed in a dry and sheltered place free of corrosive atmospheres, if possible.
- b) Since the compressor unit has passed a running test in our laboratory, the internal parts are lightly lubricated. It is however necessary to regrease the inside with an oil and gas-oil mixture, if the equipment is expected to remain inactive for a long period of time.

The machines which remain inactive after the preliminary field tests require special attention, because the accumulation of condensates within the compressor core can cause damage to the rotating parts due to oxidation as well as the blocking of the blades on the rotor housing.



CAUTION

In case that after preliminary tests or after having worked, the machine is going to be stopped for a period of time, operations indicated in chapter 7.5.- Maintenance for extended inactivity period

6. Installation, Commissioning and Operation

6.4. Site

It is important to prepare a site with the correct conditions for the equipment, ensuring that the chosen location has minimum humidity and avoiding acid and saline atmospheres.

The room where the equipment is installed must be adequately ventilated, with inlet and outlet grilles for air circulation. Avoid temperatures above 45°C.

To facilitate maintenance operations and any possible work on the equipment, you should ensure that there is easy access to the room and enough space between units to carry out partial dismantling of components.

When the total weight of the unit exceeds 250 Kg. ensure that there is a lifting system for any future manipulation of the machines.

The equipment installed outdoors must be protected with a special surface treatment and will incorporate complementary anti-rain protection.

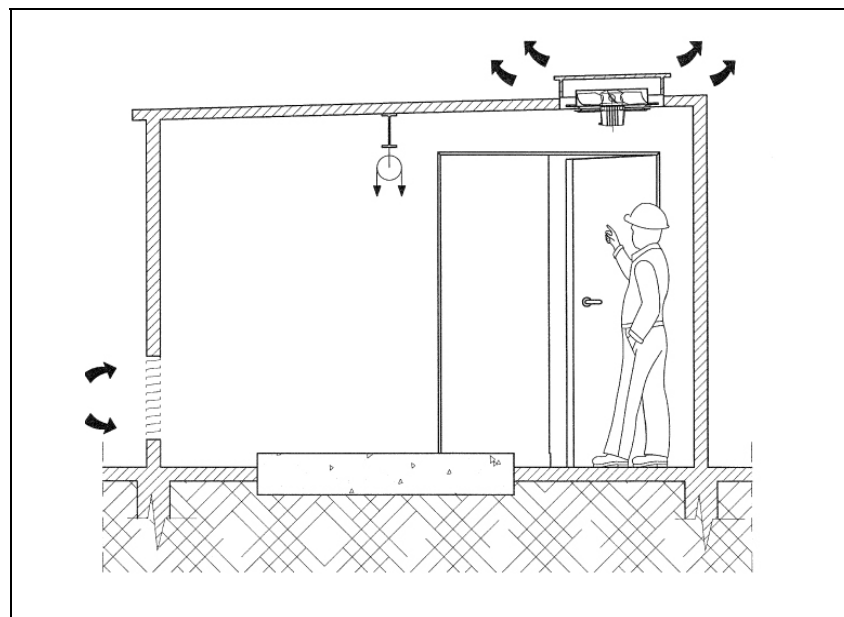

TECHNICAL MANUAL

Rotary Vanes | R/RFL G | P/PFL

6. Installation, Commissioning and Operation

6.5. Foundations and fixings

6.5.1. Installing optional items

The structural specifications of the machine room will depend on the blower unit size, weight and construction type.

The dynamic stresses of rotary machines are very low, so no extra precautions need to be taken with respect to the reinforcement and composition of the concrete foundations, which will be carried out according to standard civil works criteria.

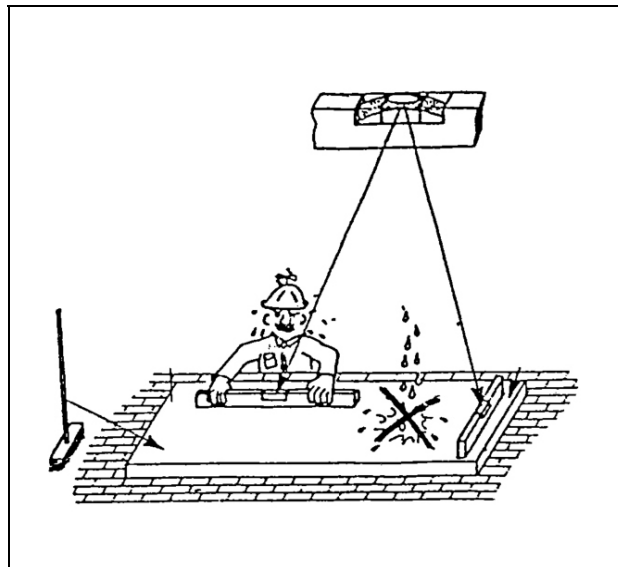

In special situations where the compressors or vacuum pumps will stand very near high-precision control and measuring rooms, the concrete foundation will have to be isolated. In such events, it will also be necessary to isolate the pipelines with elastic compensators.

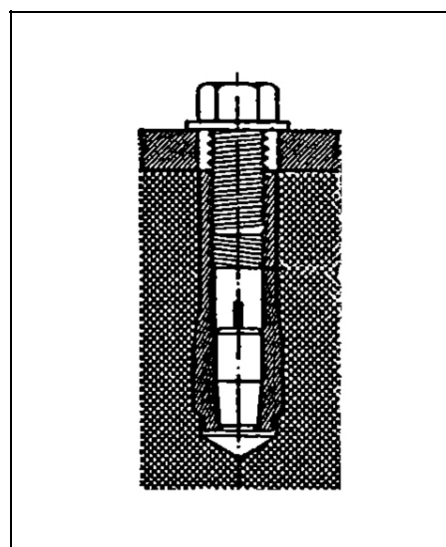

6. Installation, Commissioning and Operation



CAUTION

During any construction work, our machines and their ancillary equipment must be completely covered and protected against damage.

All packaging material must be removed from the machine placing it on the bed.

The unit must rest on dry, clean and flat foundations. The maximum slope must not exceed 0.25mm per linear metre.

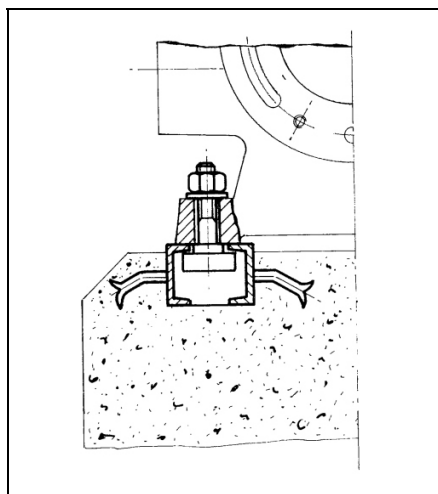

To compensate for unevenness of the support surface and to avoid deformation of the frames, the unit must be levelled using steel wedges placed as necessary beneath the frame.

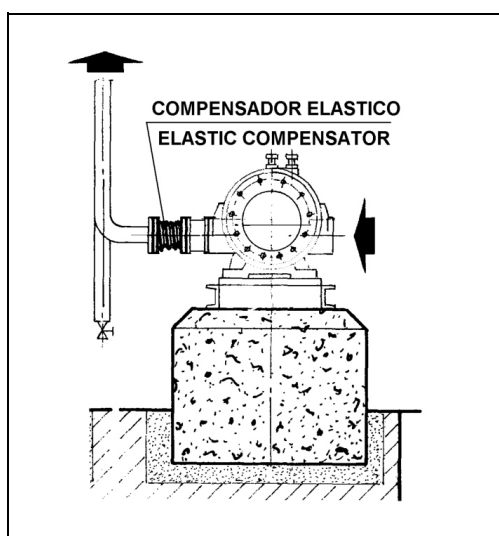

TECHNICAL MANUAL

Rotary Vanes | R/RFL G | P/PFL

6. Installation, Commissioning and Operation

The unit will be fixed (when applicable) by using conical expansion devices, chemical anchoring, bolts, etc.

When using anchor bolts, the foundations be allowed time to set before final fixing of the unit.

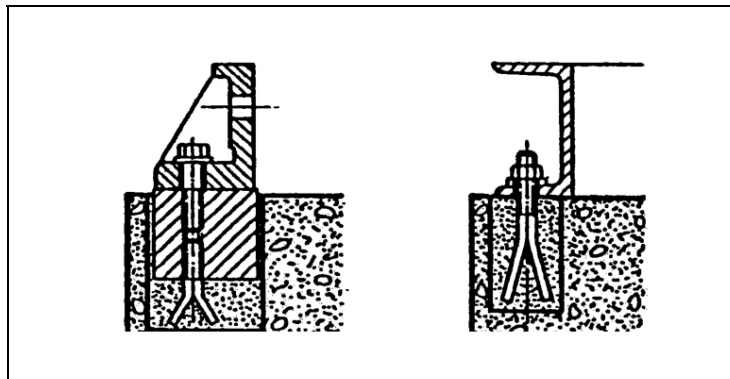

6.5.1. Installing optional items

Any ancillary items, such as separators, filters, tanks, etc... shall rest on a small concrete foundation about 250 to 300mm in height. This will permit connections to the equalising reservoirs as well as purging all the components.

The water line solenoid valve must be fitted as near the compressor or vacuum pump as possible.

Thermostats and pressure switches shall be fixed to the concrete foundation or to the wall which is closer to the unit.

Contactors and control cabinets also shall be near the machine. In plants with centralised controls, a START-STOP pushbutton must be available near the compressor or vacuum pump.

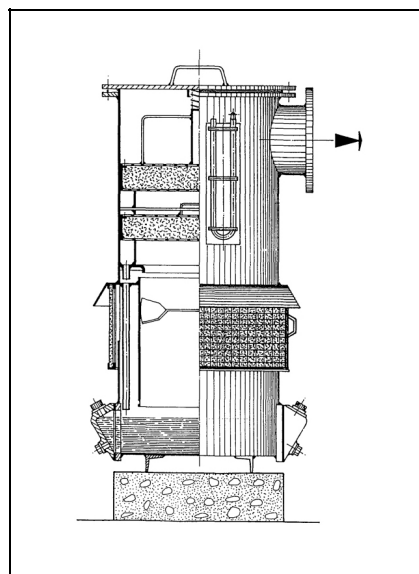

6. Installation, Commissioning and Operation

6.6. Assembly

Before the final assembly of the air ducts, it is essential to clean the inside of the tubes thoroughly and to make sure they are free from weld beads or scale which could fall off and enter the machine, causing serious damage.

We recommend that a close-woven wire mesh be fitted on the inlet orifice of the compressor or vacuum pump during its first 500 hours of operation. After this period of time, remove the wire mesh. (In the meantime, clean the wire mesh every 50 and 100 hours of service). The air ducts must be sloping lightly (1 cm per metre) in the air flow direction. At the lowest points of the air line, set a small equalising reservoir with a drain cock.

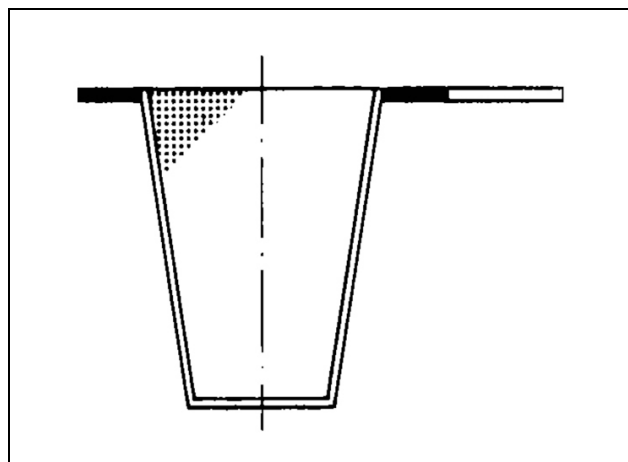

The compressed air intakes shall be situated in the upper portion of the general pipe line.

A condensate trap must obligatorily be set under the elbow of the vertical air exhaust pipe next to the compressor.

When the unit is mounted on dampers, elastic compensators have to be inserted in the fluid conveying pipes.

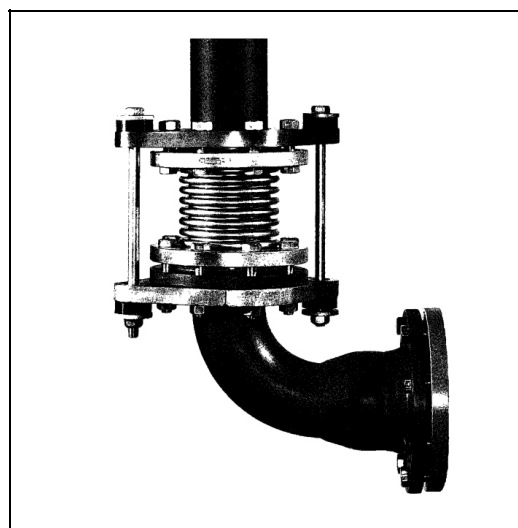

6. Installation, Commissioning and Operation

Especially when fitting fined steel compensators, the pipes before and after the compensator must be correctly fastened and the free forces resulting from elastic discontinuity must be completely absorbed by the fixing system.

If the compressor is going to be fitted with a pressure regulator, it is recommended to provide an exhaust line to the atmosphere, bearing in mind that exhaust air will contain a given amount of oil and will reach temperatures as high as 120°C

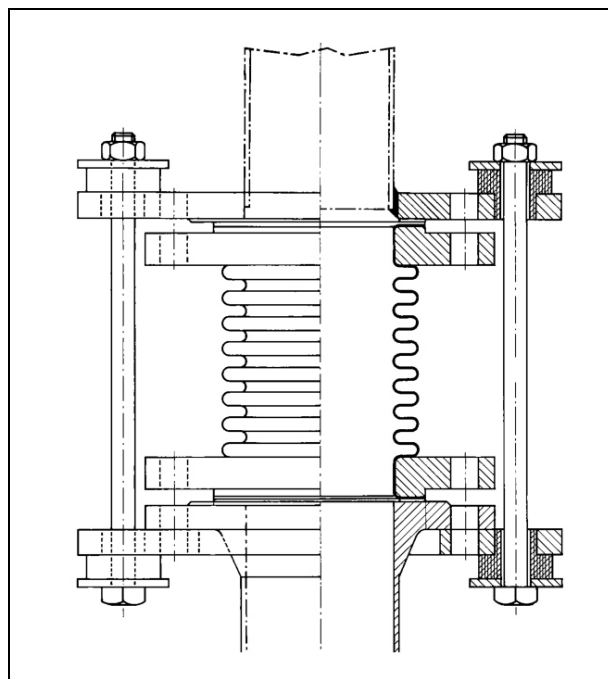

6. Installation, Commissioning and Operation

6.7. Alignment and Tensing of Pulleys and Belts

6.7.1. Alignment and Tensing of Pulleys

6.7.2. Tensing of Belts

6.7.1. Alignment and Tensing of Pulleys

The pulleys should be aligned using a steel ruler, stretched string or electronic alignment device - whichever is available.

Acceptable deviation must not exceed an angular value of $1/3^\circ$. Incorrect alignment reduces useful belt life and accelerates deformation of the pulley grooves.

The parallelism will be correct as long as the string or ruler used touches pulley points A+B+C+D.

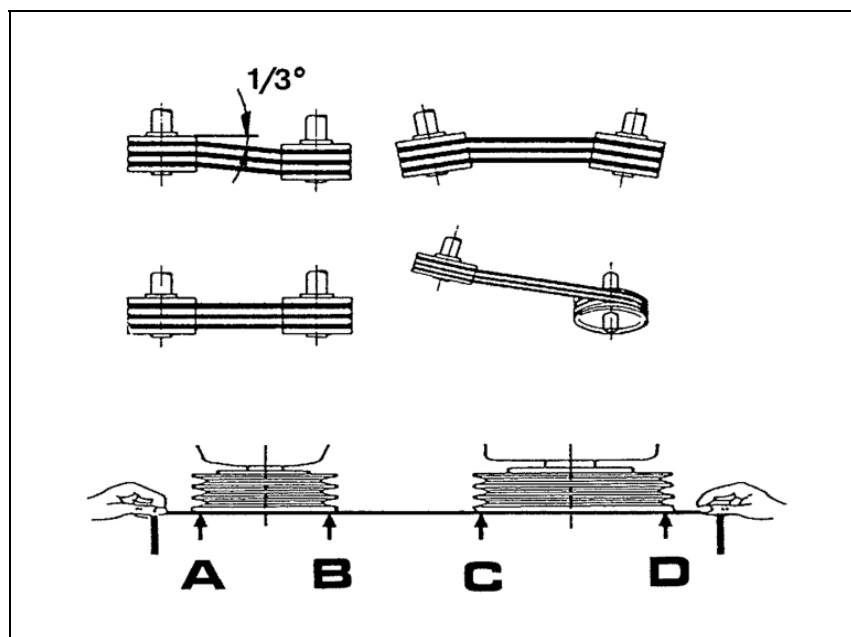

To gain access to the drive (belts and pulleys), disassemble the protective housing whenever appropriate.

Pulleys used by the drive mechanism are fitted with a taper lock bushing that adapts to the corresponding shaft.

In case the alignment values are not valid, loosen the pulley shaft by loosening the hub bolts using an Allen wrench. Once loose, by means of a calibrated ruler, move it on the shaft until the pulley position is adequate to meet the above conditions. After placing it on the correct position the screws fixing the taper lock must be tightened.

6. Installation, Commissioning and Operation

To fit, slip the slightly expanded taper lock bushing over the shaft and after alignment, lock it in position using the screws placed over the threaded holes on the pulley.

To remove it, loosen the aforementioned screws and insert them in the thread of the conical element, hitting the internal hub of the pulley lightly with a plastic hammer.

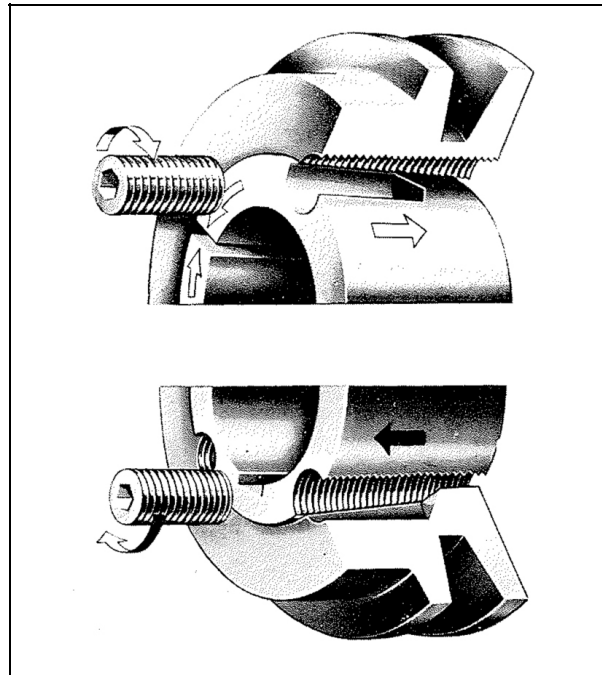

CAUTION

You should re-check the torque of the screws after the first 24 hours in operation.



WARNING

AS A PREVENTIVE MEASURE AGAINST ACCIDENTS, REMEMBER (WHERE APPLICABLE) TO INSTALL THE DRIVE PROTECTION HOUSING.

6. Installation, Commissioning and Operation

For fitting belts on the pulleys, use the takeup travel available in the stretching rail; assembly will be much easier. Never force-fit the belts, using levers, wedges or other auxiliary tools, because these could cause serious damage both to the outer wrap and to the traction fibre of the belt.

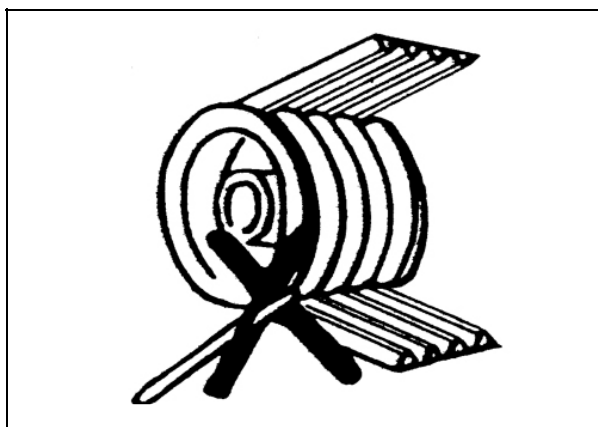

Also, before starting the assembly process, make sure the belts and pulley grooves are perfectly clean.

6.7.2. Tensing

A correct belt tension is essential to achieve optimum performance of the drive.

To set the initial tension, draw two marks (see Fig. 12) separated X mm on the central drive belt; next move the motor shaft by means of the stretching rail until the separation between the marks becomes $X+A\%$ (elongation). Under normal start-up and working conditions, the elongation percentage will be $A=0.9\%$ of X .

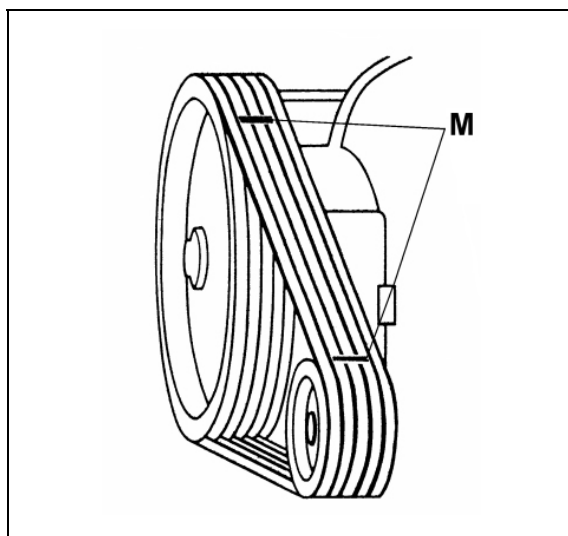

6. Installation, Commissioning and Operation

When the operation is carried out on units fitted with tension rails, belt tension will be increased gradually, verifying the value by the sag tension system. Apply a perpendicular force to the middle of belt G, using a weight, tensiometer or graduated spring showing the stress applied and verify the resulting sag, ensuring that it reaches the values shown on the following table

After 24 hours in operation, the belts should be stretched once again, given that longitudinal stability is obtained and the profile adapts to the groove during this period.

Generally speaking, the complete set of belts should be replaced in order to maintain uniform tension and load transmitted.

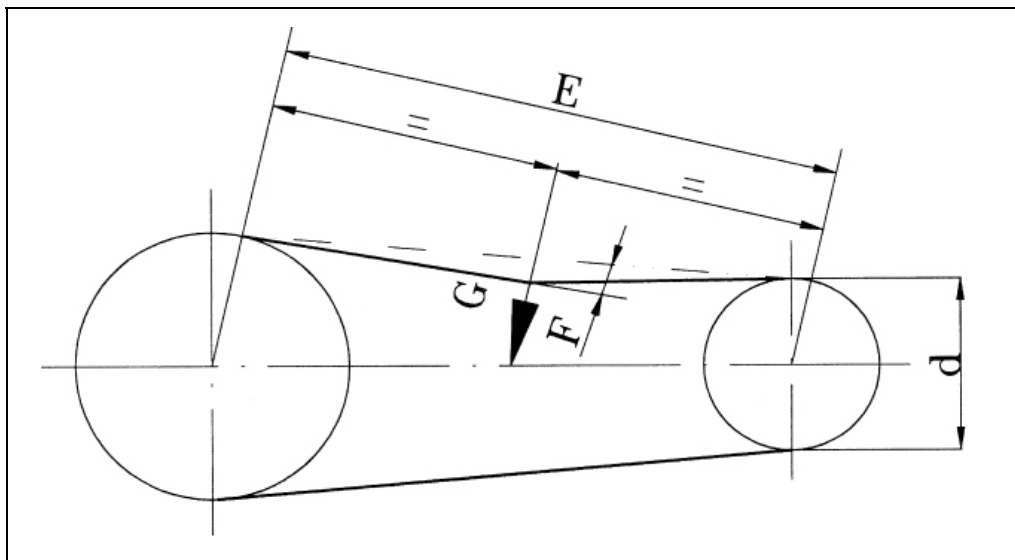

Section	Bending strength per belt (Kp)	Pulley diameter (d mm)	Sag each 100 mm from point E (mm)
SPZ	2,5	≥ 63-85	2
		> 85-106	1,8
		> 106-150	1,65
		> 150	1,4
SPA	5	≥ 85-112	2,85
		> 112-150	2,4
		> 150-224	2,15
		> 224	2
SPB	7,5	≥ 125-170	2
		> 170-236	1,5
		> 236-400	1,25
		> 400	1,15
SPC	12,5	≥ 212-265	2
		> 265-400	1,65
		> 400-560	1,6
		> 560	1,55

6. Installation, Commissioning and Operation

6.8. Flexible Coupling

Before assembling the coupling discs, clean the supporting shaft thoroughly. Use adequate mounting tools and avoid heavy hammer blows.

Make sure the coupling discs are dynamically balanced according to VDI-2060.

Check parallelism and radial alignment of the discs, using gauges and a ruler (see figure) or a dial gauge.

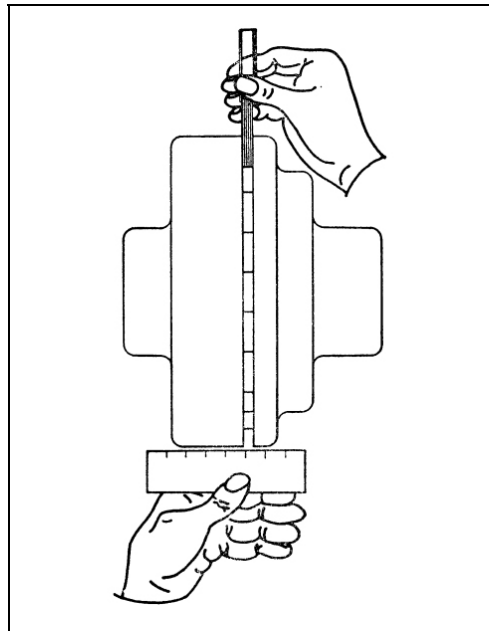

6.9. Start-up

- a) Before starting up, check the compressing (or vacuuming) plant for conformity with the project specifications.
- b) Pay particular attention to the control instruments and safety features (thermometers – pressure gauges – safety valves, etc.) as well as to the correct assembly of the pipelines within the established standards.

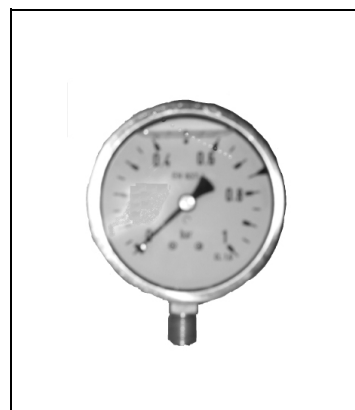

6. Installation, Commissioning and Operation

- c) Satisfy yourself that there is no blind flange in the network. Also check the cocks and plugs of the different drums and drains of the plant.
- d) Because of transport it can appear misalignments in the transmission; it must be aligned correctly before start up.
- e) First, rotate the machine by hand to make sure it rotates smoothly. Also check the flow of coolant and adjust the instruments mounted on the system.

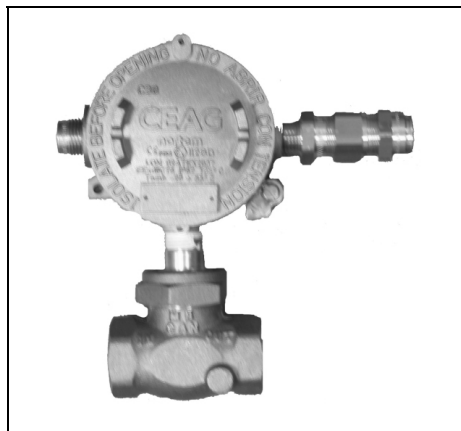

- f) Set the amount of coolant by means of the inlet regulating valve. For safety's sake, this valve should be sealed.
- g) In case that the "cooling water control switch" gives signal of lack of cooling water the stop of the motor must be setted. Compressor must never work without refrigeration.

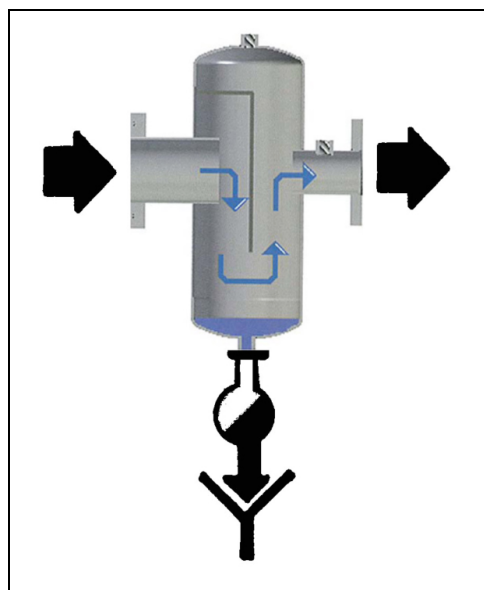

6. Installation, Commissioning and Operation

- h)** Open the cocks of the condensate traps to eliminate any water that accumulated during the assembly period.
- i)** Test the safety valve to make sure it works correctly.



- j)** Fill the lube tank with oil according to the specifications of the Recommended Oil Table. Turn the oil pump by hand until oil reaches all the oiling points. In case of MFZ pump is mounted, its electric motor must be started until oil reaches all the lubrication points.

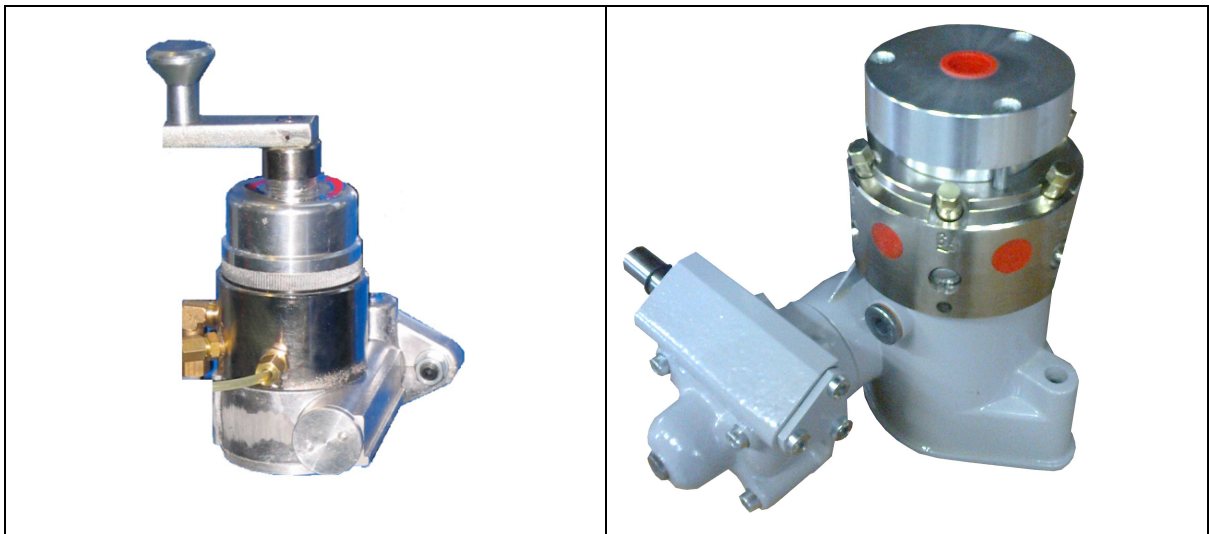

6. Installation, Commissioning and Operation

- k)** To check the correct direction of machine rotation, start the motor for a while only. Once the cooling water valve has been open, coolant must flow evenly, without air bubbles.
- l)** Clean the inside of the machine as explained further in chapter 7.4.8.
- m)** Having done the previous tasks, you can start the machine, carefully watching lubrication, air and water temperatures, pressures, etc. If you observe any unusual noise, stop the machine immediately. The safety valve shall be set at a relief pressure of 0.1 bar over the maximum rated pressure.
- n)** When stopping the compressor, close the water supply valve (manually or automatically). If the compressor is fitted with a pressure regulator and vacuuming system, the high and low pressure setting has to be carried out in accordance with the operating instructions.

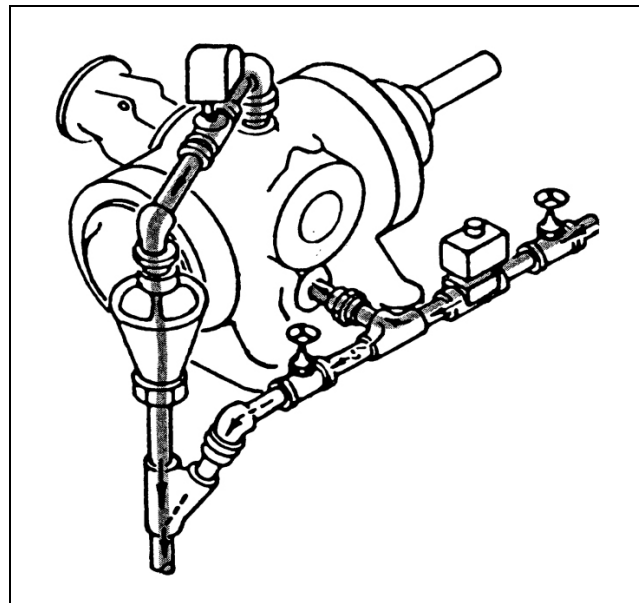



TECHNICAL MANUAL

Rotary Vanes | R/RFL G | P/PFL

7. Maintenance and Inspection

INDEX

- 7.1. Maintenance Considerations
 - 7.2. Basic Routine Maintenance Operation for Unit Maintenance
 - 7.3. Maintenance Plan
 - 7.4. Maintenance Operations
 - 7.5. Maintenance for Extended Inactivity Period
-

TECHNICAL MANUAL

Rotary Vanes | R/RFL G | P/PFL

7. Maintenance and Inspection

7.1. Maintenance Considerations



WARNING

ALL ROUTINE AND PREVENTIVE MAINTENANCE OPERATIONS ON THE MACHINES MUST BE CARRIED OUT BY QUALIFIED PERSONNEL.

THE INSTRUCTIONS AND WARNINGS LISTED ON CHAPTER 3 MUST BE CONSIDERED.



WARNING

BEFORE WORKING ON THE MACHINE, DISCONNECT THE UNIT FROM THE POWER SUPPLY, REMOVE THE FUSES AND WAIT FOR A SUFFICIENT TIME TO ALLOW THE COMPONENTS TO COOL DOWN BEFORE ACCESSING THE INTERNAL PARTS. USE APPROPRIATE PERSONAL PROTECTION EQUIPMENT. ADEQUATE PERSONAL PROTECTION EQUIPMENT MUST BE USED. THE EQUIPMENT SHOULD ALSO BE ISOLATED FROM THE REST OF THE INSTALLATION BY MEANS OF THE ISOLATING VALVES.



WARNING

BEFORE INITIAL START-UP, AFTER A PROLONGED SHUTDOWN, FAILURE OR AFTER MAINTENANCE OF ATEX EQUIPMENT, THE OPERATION OF INERTIZATION OF THE INNER PART OF THE EQUIPMENT AND ITS ACCESSORIES MUST BE CARRIED OUT PRIOR TO STARTING UP THE MACHINE.



WARNING

ANY REPAIR OR MANIPULATION IN ATEX EQUIPMENT BY PERSONNEL NOT AUTHORISED BY MAPNER WILL RESULT IN THE LOSS OF ATEX CERTIFICATION OF THE MACHINE, AND ELIMINATES THE RESPONSIBILITY OF THE MANUFACTURER IN CASE OF AN INCIDENT.



WARNING

FOR MAINTENANCE OF ATEX EQUIPMENT AND DUE TO SAFETY REASONS, ALWAYS ORIGINAL SPARES SUPPLIED BY MAPNER MUST BE USED.



CAUTION

In case that after preliminary tests or after having worked, the machine is going to be stopped for a period of time, operations indicated in chapter **7.5.- Maintenance for extended inactivity period**

TECHNICAL MANUAL

Rotary Vanes | R/RFL G | P/PFL



7. Maintenance and Inspection

7.2. Basic Routine Maintenance Operation for Unit Maintenance

- Visually check component parts.
- Check suction filter.
- Check lubricating oil level.
- Check transmission system.
- Check leak-tightness of oil compartments and fluid conduits; be sure that there is no leak.
- Check safety valves.
- Check working conditions.

Conservation operation intervals are shown in the Maintenance Plan. These intervals are indicative the will depend on the working conditions.



WARNING

IN CASE A KNOCK OR DEFORMATION OF THE TRANSMISSION PROTECTION OCCURS, IT MUST BE REPLACED IMMEDIATELY.

7. Maintenance and Inspection

7.3. Maintenance plan

Hours in Service (hrs)	CONTROL STAGES
24 hrs	<ul style="list-style-type: none"> - Check oil level and replace if applicable. - Check lubrication system. - Purge condensates drainage points. - Check the tightening of the screws of the taper lock (refer to point 6.7).
1.000 hrs	<ul style="list-style-type: none"> - Check and clean if applicable inlet filter (refer to point 5.3.3.)
2.000 hrs	<ul style="list-style-type: none"> - Check non-return and safety valves (refer to points 5.3.1 and 5.3.2). - Check transmission tension and coupling alignment (refer to point 6.7).. - Check blades wear (refer to point 7.4.3.1.). In case of blades replacement, clean machine core (refer to point 7.4.3.4.).
3.000 hrs	<ul style="list-style-type: none"> - Check safety and control elements
4.000 hrs	<ul style="list-style-type: none"> - Check and replace if applicable inlet filtering elements (refer to point 5.3.3.). - Check cooling system, in case cleaning is needed refer to point 7.4.8.
10.000 hrs	<p>General inspection of the core by MAPNER technical assistance service</p> <ul style="list-style-type: none"> - Clean oil tank filtering element.- - Partial or total disassembly of machine if applicable (refer to points 7.4.6 and 7.4.7).. - Check bearings, retains, segments... - Check stator bore inlet surface. - Check cleaning and parallelism of rotor housings. - Check transmission elements. - Check blades wear (refer to point 7.4.3).



CAUTION

Scrupulously respect the lubrication intervals (if appropriate) of electric drive motor bearings as stated on the lubrication plate and in the manufacturer's instructions.

The machine elements that in any inspection present deterioration or wear away must be replaced



NOTE

Always indicate machine serial number shown in tag plate in order to request spare parts for a machine.

TECHNICAL MANUAL

Rotary Vanes | R/RFL G | P/PFL

7. Maintenance and Inspection

7.4. Maintenance operations

- 7.4.1. Lubrication
- 7.4.2. Motors
- 7.4.3. Blades
- 7.4.4. Bearings
- 7.4.5. Compression segments
- 7.4.6. Disassembly
- 7.4.7. Assembling
- 7.4.8. Cleaning of the refrigeration chamber

7.4.1. Lubrication

- 7.4.1.1. Start-up
 - 7.4.1.1.1. Pump type (IT.2-IT.4-IT.6)
 - 7.4.1.1.2. Pump type MFZ
- 7.4.1.2. Adjustment
 - 7.4.1.2.1. Type: IT.2 – IT.4 – IT.6
 - 7.4.1.2.2. Type: TK
 - 7.4.1.2.3. Type: MFZ

Using high quality lube oil is essential to get optimum performance from the compressors and vacuum pumps.

We recommend using the oils listed in the lubricant chart or products of similar characteristics. Do not mix oils of different makes and check that the oil you use contains antioxidants and antifoam additives.

Spare oil drums must be kept hermetically closed in order to prevent air moisture absorption.

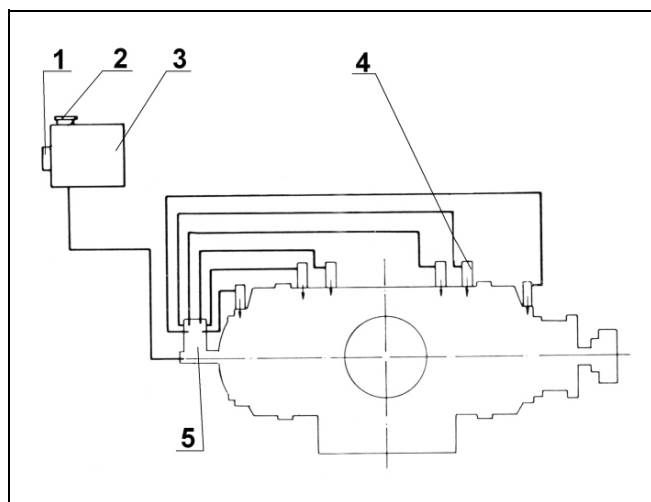

1. Alarm unit (optional)
2. Filling plug
3. Oil tank
4. Lubricator (built in valve)
5. Oil pump

TECHNICAL MANUAL

Rotary Vanes | R/RFL G | P/PFL

7. Maintenance and Inspection



CAUTION

Compressors and vacuum pumps are supplied WITHOUT LUBE OIL.



NOTE

The location and number of oiling points vary, depending on the type of the machine. (See attached lubrication table)

RECOMMENDED OILS					
CLIMATE	PRODUCER	TYPE	VISCOSITY ISO VG DIN 51 519	FREEZING POINT °C	FLASH POINT °C
HOT	AGIP	AGIP ACER 320	320	-14	274
	BP	ENERGOL - HLP - 320	320	-24	270
		ENERGOL - CS - 320	320	-9	271
	CEPSA	HD TURBINAS 320	320	-9	260
	ESSO	SPARTAN EP 320	320	-18	265
	KLUBER	KLÜBEROIL GEM 1-320 N	320	<-10	>220
	VERKOL	NAVAPAR HM-320	320	-9	272
NORMAL	AGIP	ACER 220	220	-10	235
	REPSOL	ARIES. 220	220	-9	240
	CALVO SOTELO	PREMIUM SAE.50	220	-15	240
	CEPSA	PREMIUM AX. SAE 50	220	-13	260
	ERTOIL	ODIEL 220	220	-12	270
	ESSO	SPARTAN EP 220	220	-24	255
	CFR TOTAL	CORTIS 170	220	-13	275
	GULF OIL	MARMONY 97	220	-18	277
	ANTAR S.A.	MISOLA FH	220	-15	280
	AMALIE	AMALIE SAE.50	220	-13	254
	HOUSTON	HIDRAUFLUIDE MIH 50	220	-16	265
	KLUBER	KLUBEROIL GEM 1-220 N	220	<-10	>200
	VERKOL	COMPOUND E-3 / ISO-220	220	-12	243
COLD	REPSOL	ARIES 150	142	-9	230
	CEPSA	PREMIUM AX. SAE. 40	150	-12	242
	ERTOIL	ODIEL 150	150	-12	250
	KLUBER	KLUBEROIL GEM 1-150 N	150	<-10	>200
	VERKOL	NAVAPAR HM-150	150	-12	264

7. Maintenance and Inspection

LUBRICATION					
TYPE	Lubrication points	Drops per minute	TYPE	Lubrication points	Drops per minute
R.15	2	7	R.201	6	12
R.20	2	7	R.250	6	12
R.25	2	8	R.300	6	12
R.30	2	8	R.400	6	12
R.40	4	7	R.500	6	12
R.50	4	8	R.600	6	13
R.60	4	8			
R.70	4	9	RFL.15	2	7
R.80	4	9	RFL.20	2	7
R.100	4	9	RFL.25	2	8
R.120	4	10	RFL.30	2	9
R.121	4	10	RFL.40	4	7
R.150	6	9	RFL.50	4	8
R.180	6	9	RFL.60	4	9
R.190	6	10			
R.200	6	11	PFL.250	2	8
			PFL.500	4	10
			PFL.750	4	11

Oil Pumps

Permanent lubrication of the rotary machines' components is achieved by the amount of oil supplied by the automatic pump at regular intervals.

The distribution system with independent pistons makes it possible to supply the specified amount of oil to each oiling point.

Coupling and pipe connections

Before mounting the oil pump in the machine housing, check the condition of the grooved block fitted on the rotor.

Verify that the ends of the tubes and connectors are in good conditions, so as to ensure perfect tightness of the lubricating circuit.

TECHNICAL MANUAL

Rotary Vanes | R/RFL G | P/PFL

7. Maintenance and Inspection

7.4.1.1. Start-up

Before filling the oil tank, make sure the inside of the tank and the filter are clean.

7.4.1.1.1. Pump type (IT.2-IT.4-IT.6)

Once the supply tank has been filled up, prime the pipes by operating the pump manually: press the lever (1) down and turn it anticlockwise until oil starts dropping in each of the lubrication indicators situated on the machine.

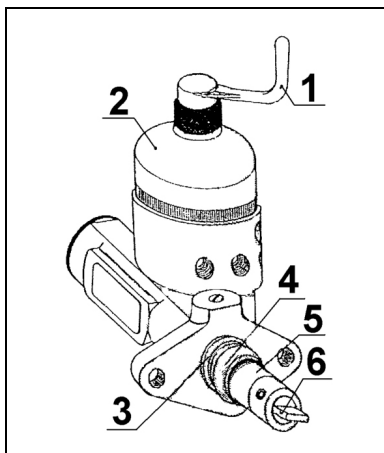

TYPE: IT.2 - IT.4-IT.6

1. Operating lever
2. Cover supporting the operating lever
3. Retainer friction ring
4. Graphite retainer
5. Retainer supporting bush
6. Coupler

This being done, stop pushing the lever; it will get back to its initial position and the pump will be ready to operate automatically when the machine is running.

7.4.1.1.2. Pump type MFZ

Once the supply tank has been filled up, prime the pipes by starting motor pump, until oil starts dropping in each of the lubrication indicators situated on the machine.

The motor connection to the control cabinet must be made according to the wiring diagram.

7.4.1.2. Adjustment

According to the characteristics and type of the machine (see table on page 7-37), 3 to 10 drops of oil per minute should pass through each lubrication indicator.

Insufficient lubrication reduces efficiency, causing unusual wear and, at times, severe seizure.

TECHNICAL MANUAL

Rotary Vanes | R/RFL G | P/PFL

7. Maintenance and Inspection

7.4.1.2.1. Type : IT.2 - IT.4 - IT.6

If the amount of oil in one of the indicators is excessive, locate the adjusting screw associated with this oiling point and turn it clockwise (-). If there is not enough lubrication, turn the adjusting screw progressively anticlockwise (+) until the specified amount is reached.

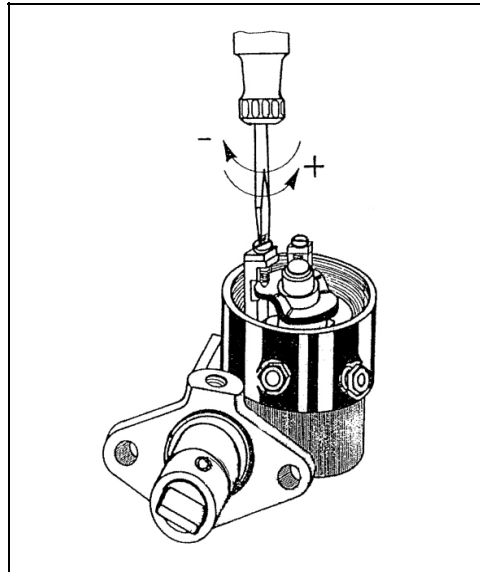

7.4.1.2.2. Type: TK

Remove the cover ref.1 in order to reach screws ref.2

If the amount of oil in one of the indicators is excessive, locate the adjusting screw (2) associated with this oiling point and turn it anticlockwise (-). If there is not enough lubrication, turn the adjusting screw progressively clockwise (+) until the specified amount is reached.

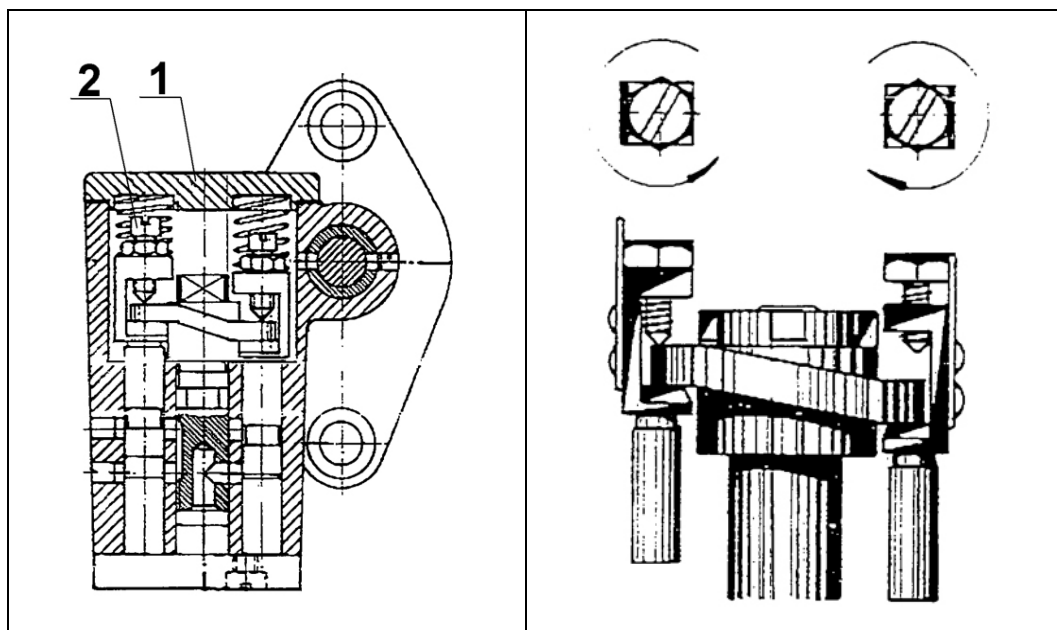

TECHNICAL MANUAL

Rotary Vanes | R/RFL G | P/PFL

7. Maintenance and Inspection

7.4.1.2.3. Type: MFZ

The adjustment is made by turning the head of the adjusting spindle. Turning the spindle to the right reduces the amount of lift, thus reducing the amount of oil. To increase the amount of greasing, turn the spindle to the left.

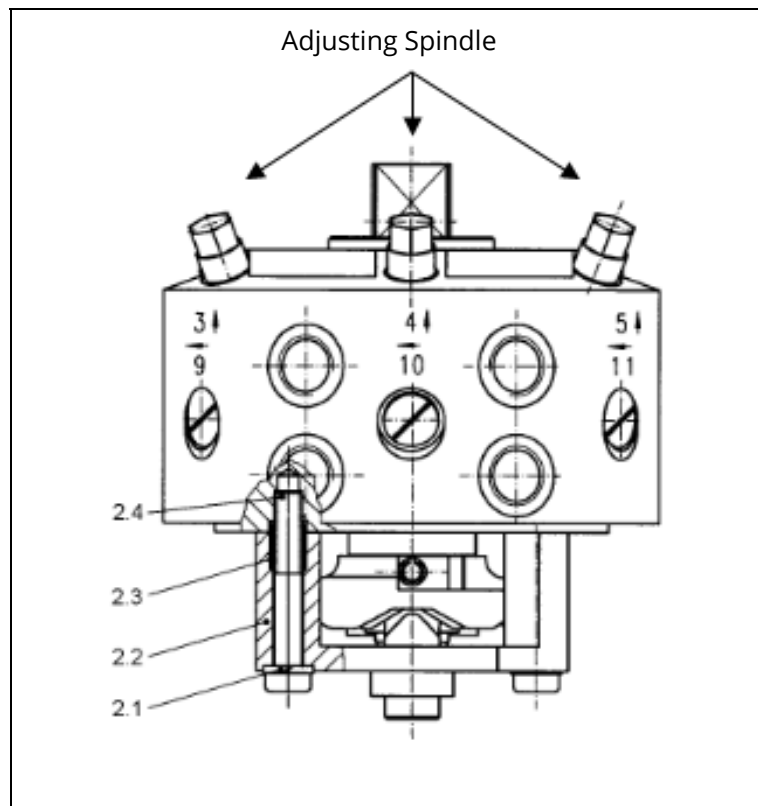

Troubles with the lubricating system

Any ingress of air into the circuit, however small this can be, may cause serious disorders or even complete failure of the lubricating system.

Extremely cold temperatures impedes oil to enter the pump normally, which in turn results in erratic performance of the lubricating system. For operation under those circumstances, we recommend that a heating resistor be fitted into the oil supply tank.

When the oil tank filter gets clogged, oil has difficulty reaching the pump, which makes the lubricating system inoperative (check the filter periodically).

7. Maintenance and Inspection

Presence of air in the oil drops.

(a) compressor

- 1.- Inlet connector to the pump improperly closed; faulty bicones or bolster
- 2.- Foreign bodies on the oiler ball seat.

(b) vacuum pump

- 1.- Inlet connector improperly closed or defective.
- 2.- Screw (x) in the oiler head improperly fastened or damaged gasket.
- 3.- Defective glass sealing gasket.
- 4.- Glass tube broken.

REMARKS

- (a) Oil is under pressure up to the oiler valve, and then falls by gravity.
- (b) On vacuum pumps, and generally in stages 1 and 2, it may happen that the drop breaks inside the oiler. This is due to the transformation of the oil moisture
- (c) The level between the pump of distribution of oil and oil supply tank does not have to exceed 500mm.

Built-In flap valve

Through the sight glass, the operator can check the amount of lube oil injected by the oil pump into the different oiling points on the machine.

The built-in flap valve in the head of the lubricator must continually impede air from being sucked in or entering the lubricating circuit.

Periodic checks

- (a) Remove the cap (G) and clean any waste oil off the ball and seat.
- (b) Periodically check the lubricating circuit's pressure. To do so, insert a dial pressure gauge between the oil pump and the indicator. (Back pressure should not exceed 8-12kg/cm²).
- (c) Tightness problems with the oil indicator due to damage of the glass tube (generally unseen from outside) or wear of the O-rings may give rise to disadjustments in oil dropping monitoring

Lubrication cannot be reduced on vacuum pumps

- 1.- Incorrect closing of the oiler flap valve due to foreign body build-ups on its seat.
- 2.- Excessive clearance of the pump's pistons.
- 3.- Spring of the oiler flap valve strained.

TECHNICAL MANUAL

Rotary Vanes | R/RFL G | P/PFL

7. Maintenance and Inspection

The visible drop lubricators get filled with oil

- 1.- The sealing gaskets of the glass tube are defective.
- 2.- Valve spring fixing screw loose or sealing gasket damaged.
- 3.- Outlet orifice plugged.

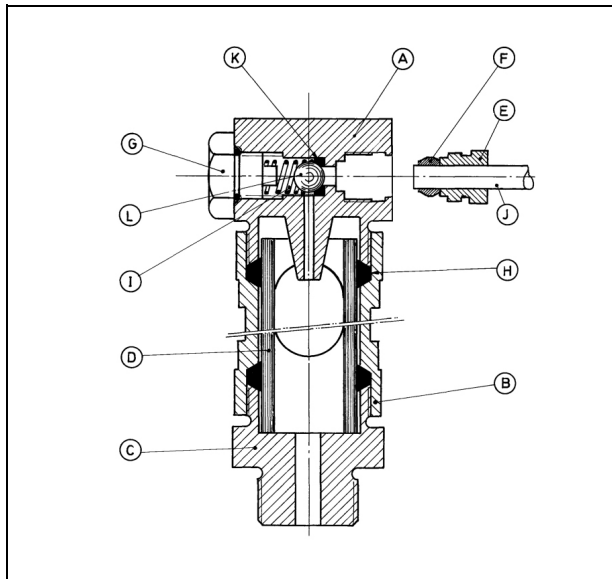

- A. Flat valve head
- B. Barrel
- C. Base
- D. Sight glass tube
- E. Connector
- F. Bicone
- G. Cap
- H. Gasket
- I. Spring
- J. Piping
- K. Gasket
- L. Ball

7.4.2. Motors

In selecting the electric motors for our machines, we take account of the specific characteristics of the project concerned and the input power that depends on the flow rate and differential pressure. Before powering the motors, carefully read and follow the instructions contained in the motor manufacturer's manual.

Under no circumstances shall the current stated on the motor rating plate be exceeded. When using a frequency variator, be especially attentive to the low frequency limit, on both the motor and machine sides. If in doubt, contact the manufacturer.

Lubrication

The motors come with heavy grease lubricated bearings. Grease must be free from resin and acid; it should not solidify nor clot. Its dropping point must be at least 160°C. We recommend using the following greases:

- KALOL VERKOL RF lithium grease
- SHELL Grease Albania 3.
- ESSO Beacon 3.
- SKF 28 o 63.

Do not mix greases of different properties.

There are two possible motor lubricating methods: (A) through a conventional greaser or (B) with a lubricating valve.

7. Maintenance and Inspection

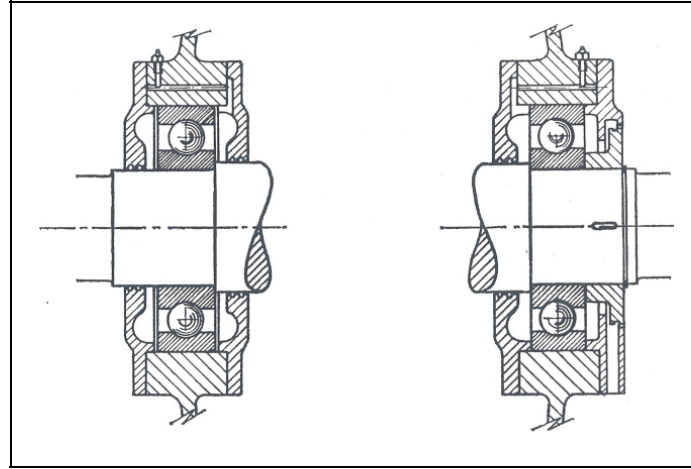

Fig.A

Fig.B

Remember that motor efficiency decreases depending on the altitude (height above sea level) and ambient temperature at the place of operation, in accordance with Table 1.

A number of starts per hour as specified in Table 2 are acceptable if the following requirements are met:

"additional moment of inertia equal to or less than the rotor moment of inertia; resisting torque squared with the number of revolutions until reaching the impressed torque; starts at uniform intervals".

If you need a greater number of starts per hour, contact the manufacturer.

Ambient temperature °C	30	40	45	50	55	60	70	80
Permitted power % of nominal power	107	100	96,5	93	90	86,5	79	70

Sea level height (m)	1000	1500	2000	2500	3000	3500	4000
Permitted power % of nominal power	100	96	92	88	84	80	76

Table 1.

STARTINGS/HOUR ADMISIBLE						
Shaft high						
N° poles	56-71	80-100	112-132	160-180	200-225	250-315
2	100	60	30	15	8	4
4	250	140	60	30	15	8
≥ 6	350	160	80	50	30	12

Table 2.

TECHNICAL MANUAL

Rotary Vanes | R/RFL G | P/PFL

7. Maintenance and Inspection

7.4.3. Blades

7.4.3.1. Wear control

7.4.3.2. Partial disassembly

7.4.3.3. Fitting the "Mapner" blades

7.4.3.4. Cleaning

7.4.3.5. Storing blades

7.4.3.1. Wear control

- (a) Remove the plugs or connectors placed longitudinally along the stator axis at the top of the stator.
Introduce the control rod down to the diametrical surface of the rotor and draw a mark (A).
Turn the rotor by hand, the rod will enter a slot and touch the blade. In this position, draw a second mark (B). The height difference of the two marks indicate the amount of wear (H).
- (b) Blade wear has to be checked every 2000 hours of operation.
Replace the blades when wear reaches the maximum permissible value.

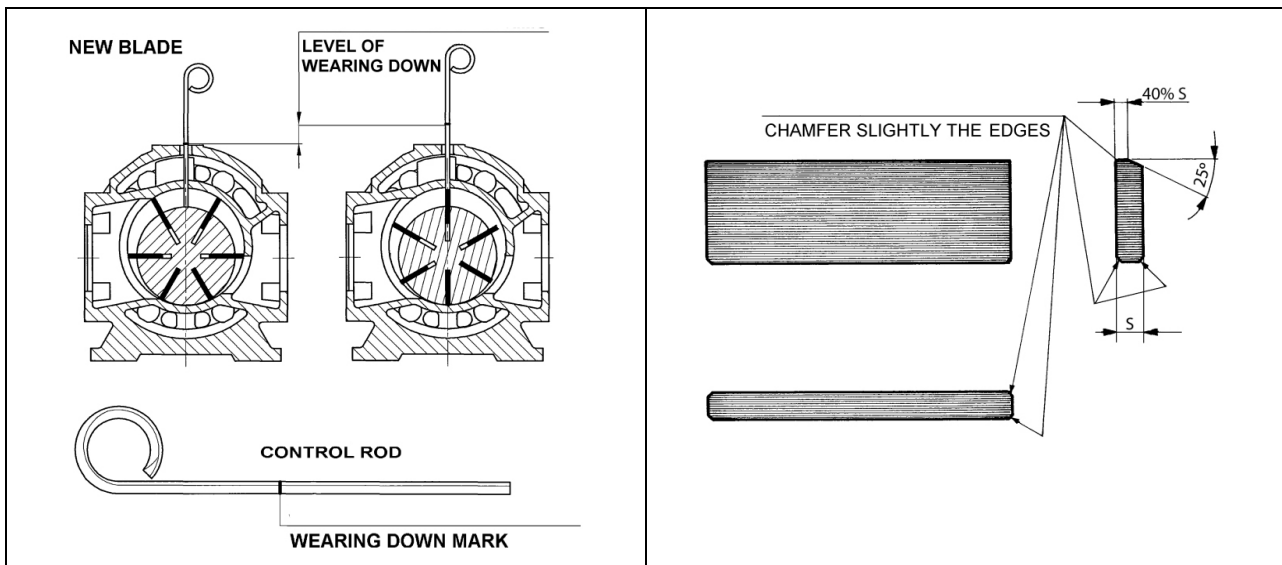

TECHNICAL MANUAL

Rotary Vanes | R/RFL G | P/PFL



7. Maintenance and Inspection

Maximum allowable wear table

BLADES							
TYPE	ORIGINAL DIMENSIONS	MAXIMUN WEAR	INSIDE CLEANING QUANTITY	TYPE	ORIGINAL DIMENSIONS	MAXIMUN WEAR	INSIDE CLEANING QUANTITY
R/P.15	180.47.4,76	10	75 cc	R/P.201	850.103.9,5	12	1 lt
R/P.20	180.47.4,76	4	75 cc	R/P.250	1000.120.12,7	18	1 lt
R/P.25	300.52.6,35	15	100 cc	R/P.300	1280.120.12,7	18	1 lt
R/P.30	300.52.6,35	11	100 cc	R/P.400	1000.160.12,7	14	1,5 lt
R/P.40	400.54.6,35	12	200 cc	R/P.500	1300.160.12,7	14	1,5 lt
R/P.50	400.54.6,35	7	200 cc	R/P.600	1570.170.12,7	22	1,75 lt
R/P.60	440.70.9,5	15	300 cc	RFL.15	220.47.6,35	12	75 cc
R/P.70	440.70.9,5	10	300 cc	RFL.20	220.47.6,35	10	75 cc
R/P.80	625.70.9,5	15	400 cc	RFL.25	300.47.6,35	12	100 cc
R/P.100	625.70.9,5	8	400 cc	RFL.30	300.47.6,35	10	100 cc
R/P.120	670.88.9,5	11	500 cc	RFL.40	400.54.6,35	12	200 cc
R/P.121	745.78.9,5	15	500 cc	RFL.50	480.54.6,35	12	200 cc
R/P.150	850.94.9,5	18	500 cc	RFL.60	570.54.6,35	12	250 cc
R/P.180	850.103.9,5	17	750 cc	PFL.250	176.70.6,35	15	100 cc
R/P.190	850.103.9,5	12	750 cc	PFL.500	352.70.6,35	15	200 cc
R/P.200	850.110.9,5	10	1 lt	PFL.750	528.70.6,35	15	250 cc

7.4.3.2. Partial disassembly

(1) In order to reach the blades, disassemble the machine in the following order: oil pump (inexistent on some models) with its piping, the AR rear cover, the bearing fixing nut (generally right-hand thread, but there are exceptions). Back off the nuts from the AR rear cover, after verifying that the cooling circuit is totally empty (if you have a water-cooled machine). Remove the cover using two BTR extraction screws inserted in two diametrically opposed holes. Detach the paper gaskets from the cover. The NU bearing will come out with the cover.

Careful with the compression segments, if any. See the specific instructions for compression segments on separate sheets

(2) Back off the fixing nuts from the AV front cover. Take the rotor out of the stator, with the AV front cover and its retainer, as well as the half-coupling. To avoid changes in adjustment, do not disassemble unnecessarily the unit composed of the rotor, front bearing, front cover and sealing retainer.

TECHNICAL MANUAL

Rotary Vanes | R/RFL G | P/PFL

7. Maintenance and Inspection

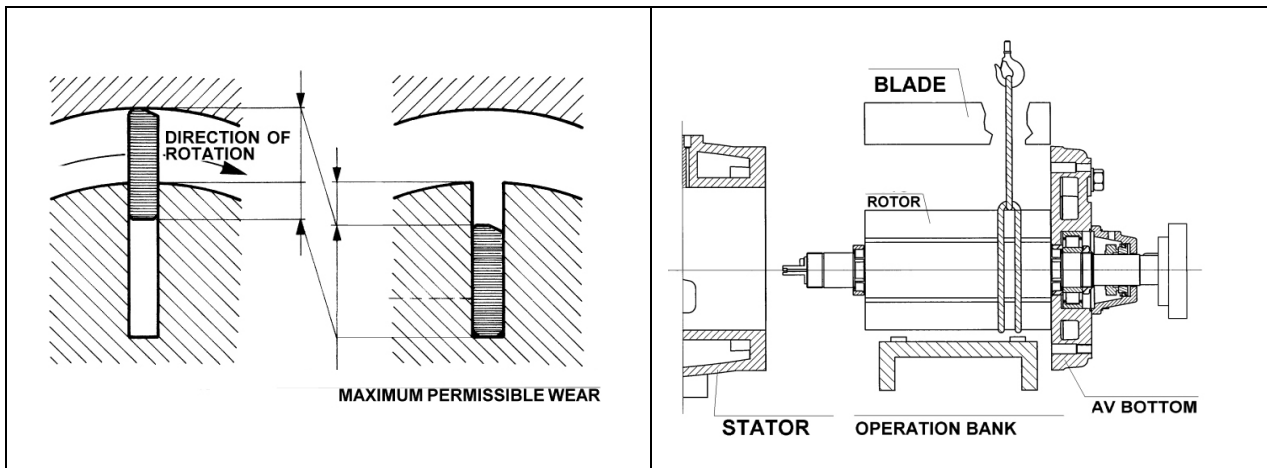

7.4.3.3. Fitting the “Mapner” blades

Before fitting used blades, check them for good condition and wear. Under no circumstances shall wear exceed the limits specified on the machine's technical datasheet.

On blades that have been previously used, the surface in contact with the stator shall have a barrelled and bright aspect. DO NOT file nor rework this area; just smooth out the sharp edges lengthwise.

When fitting new blades, you will notice that the original thickness is slightly greater than the slot width. This is in anticipation of changes to the housings due to wear.

Carefully set each blade in its slot, sanding it with a fine-grained sander.

Check to see if there is any jam point and if the blade moves freely in its housing.

NOTES

- The blades which are in contact with basic gases get thicker; therefore, a greater slot clearance is required.
- DO NOT mount new blades if the stator bore surface shows wavy areas, scratches or substantial distortions.
- Since the breaking of one or various blades generally entails cracks in the lower area (eccentricity) of the stator, this area must be inspected before mounting new blades.

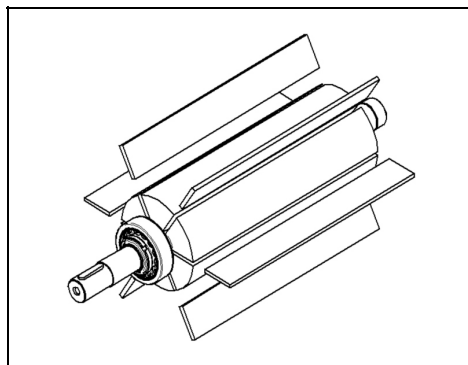

7. Maintenance and Inspection

7.4.3.4. Cleaning

Use anti-rust product in order to clean the inside of the stator and, principally, the inlet and discharge nozzles. Also, clean the rotor slots, bearings, covers, etc. thoroughly.

Inspect the cooling chambers of the stator and covers (water-cooled machines) and remove scale and/or deposits. Clean refrigeration chamber according to what indicated on chapter 7.4.8.

Before definitively placing the blades in their housings, lubricate them with plenty of oil, using the same lube oil as is used for lubricating the machine.

After inserting the blades in their housings, make sure they do not protrude over the diametrical size of the rotor.

7.4.3.5. Storing blades

Tener la precaución de almacenar las láminas, en locales adecuados, manteniendo siempre su envoltorio original.

La superficie de apoyo deberá estar perfectamente plana, para evitar deformaciones muy difíciles de corregir.

TECHNICAL MANUAL

Rotary Vanes | R/RFL G | P/PFL

7. Maintenance and Inspection

7.4.4. Bearings

7.4.4.1. Assembly

7.4.4.2. Disassembly

7.4.4.3. Storing the bearings

The bearings used in the construction of MAPNER Compressors and Vacuum Pumps are NU-NH series cylindrical roller bearings with specific axial and radial tolerances equivalent to grade C4. As a consequence, all the bearings supplied as spares by MAPNER come with the axial and radial play conforming to the said group of tolerances. In general, 'standard' commercial bearings belong to class C2 and C3, which have play values lower than the recommended ones.

7.4.4.1. Assembly

BEARING NH

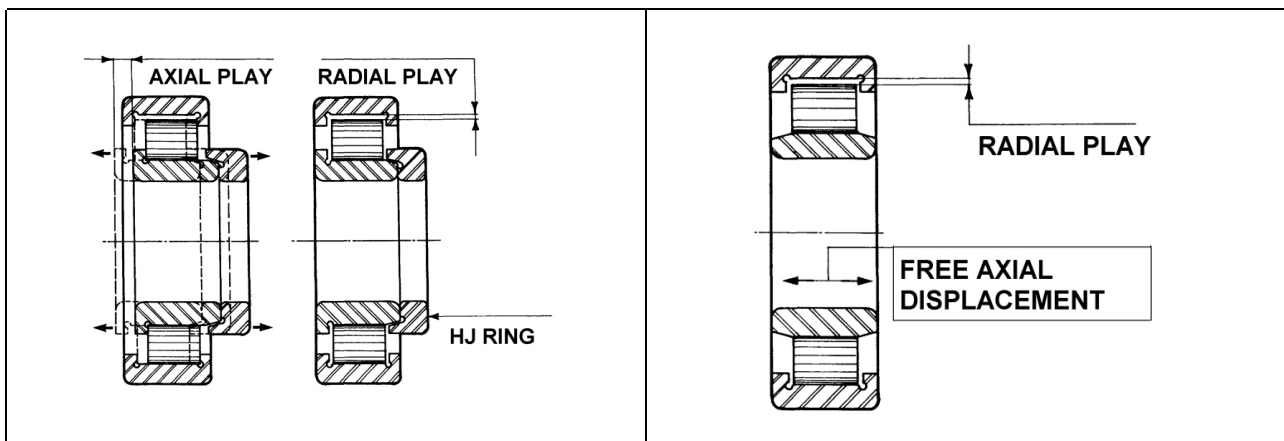

- (a) Clean and check the bearing housing in the rotor.
- (b) Warm the inner race of the bearing by induction and in an oil bath. This, ensures uniform heating and adequate temperature – 100 to 120°C – for an adequate expansion of the race. As a protection and safety measure, we recommend that a thermostat be placed.

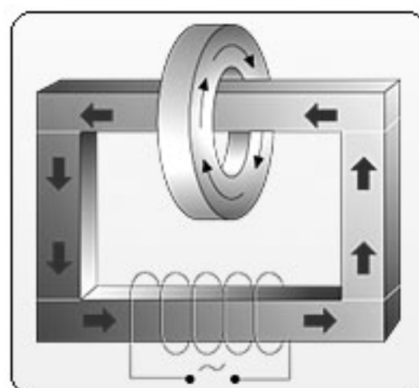

TECHNICAL MANUAL

Rotary Vanes | R/RFL G | P/PFL

7. Maintenance and Inspection

- (c) When heated, remove the race and place it in front of its housing, in such a way that it can be inserted quickly into the front supporting area (collar) without getting blocked. When handling hot races, wear asbestos gloves or use a clean, lint-free cloth, avoiding cotton insofar as possible. Immediately after sliding the race into its front support, lock it with the fixing nut. Tighten the nut strongly (Fig. 1). If this operation has been done correctly the front supporting collar shall not move in any direction.

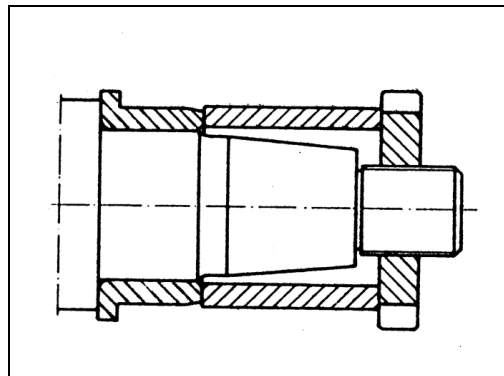

Fig.1

- (d) With thickness gauges, check the radial play of the bearing, by fitting the outer race (roller-holder). NEVER force to set the outer race, since you might damage the rolling track of the inner race.
- (e) As a rule, always mount the bearings with the stamped reference mark facing outwards

7.4.4.2. Disassembly

If the bearings are to be reused, the force required to disassemble them shall by no means be applied onto the rolling elements. Choosing an adequate tool will depend on the bearing size and available room.

To disassemble damaged bearings that will not be reused, apply heat direct from a blowtorch, quickly and in a concentrated manner to prevent the shaft from expanding at the same time as the race.

With two levers (Fig. 2), you will be able to extract the race easily.

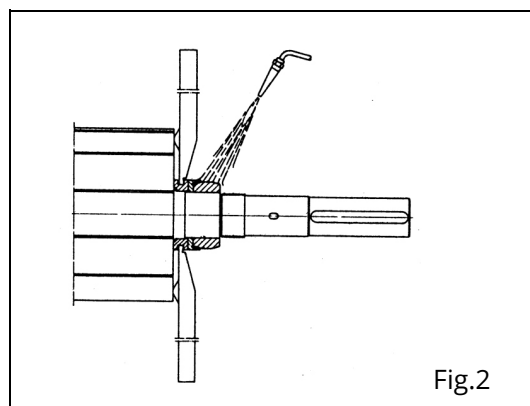

Fig.2

TECHNICAL MANUAL

Rotary Vanes | R/RFL G | P/PFL

7. Maintenance and Inspection

7.4.4.3. Storing the bearings

The bearings are factory-supplied with a rust-preventive protection. They should be stored in their original package until used. For perfect conservation, choose a clean and adequate place, avoiding humid, acid and salt atmospheres insofar as possible.

TECHNICAL MANUAL

Rotary Vanes | R/RFL G | P/PFL

7. Maintenance and Inspection

7.4.5. Compression segments

7.4.5.1. Disassembly

7.4.5.2. Assembling the segments

The compression segments lie on the supporting collars and remain static under the effect of the expanding force which is necessary to hold them against the bore of the cover.

The side faces of the segment rub lightly against the housing of the collar that rotates and ensures there is always a lubricating oil film.

7.4.5.1. Disassembly

To gain access to the segment, it is necessary to disassemble the cover. In order to extract the segment from its seat easily, introduce three symmetrically arranged metal wedges between the collar and the segment. DO NOT open the segment excessively in order not to break it. Inspect the diametrical surface of the segment and bore; there should not be any sign of friction caused by the segment rotation. Please contact us about the maximum permissible boring of the cover. The side faces of the seat and segment should be free from seizure marks. If there are important seizure marks, change the collar and the segment.

Carefully clean the segment, seating slot and cover with petroleum-gas oil or another suitable product. Take care not to leave any cloth or cotton debris in the slot.

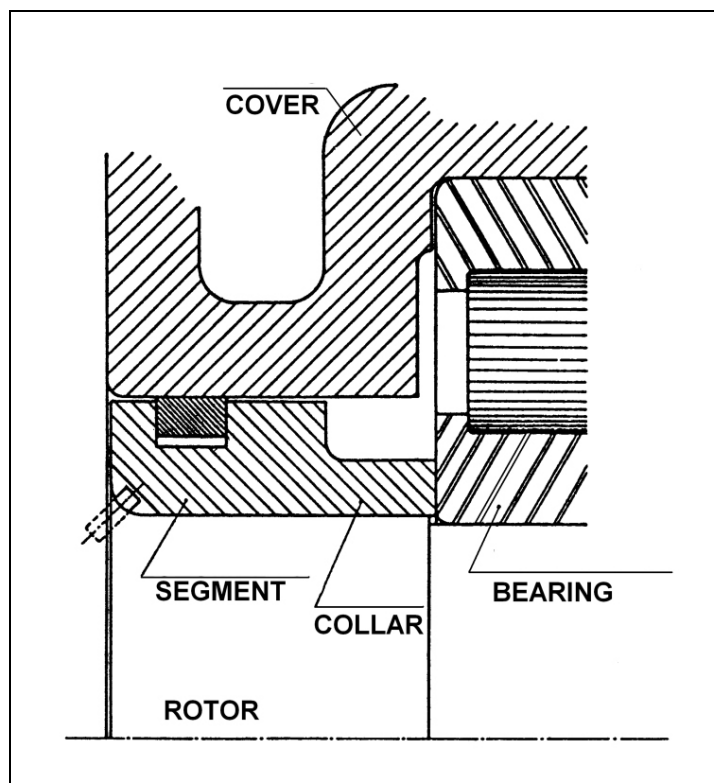

TECHNICAL MANUAL

Rotary Vanes | R/RFL G | P/PFL

7. Maintenance and Inspection

7.4.5.2. Assembling the segments

1. Set the segment into the bore of the cover and check the cut tolerance with a gauge. See Table.
2. Insert the segment into the seating slot in the supporting collar.
3. Axial clearance between the segment faces and the slot vary from 3/100 to 5/100 according to size.
4. Lubricate the segment and its housing, using oil or Molykote grease.
5. Join the two ends of the segment, pressing on the outside of the segment with a piano wire or similar rope, as shown on the bottom figure.
6. Place the cover in front of the segment, inserting it approximately half-way of its length.
7. Hold the cover in this position and remove the wire. The segment will expand, occupying the bore of the cover.
8. Push the cover against the end of the rotor, set the outer race (roller-holder) of the bearing and fasten the nut against the inner race.

MAPNER COMPRESSION SEGMENT MOUNTING TOLERANCES

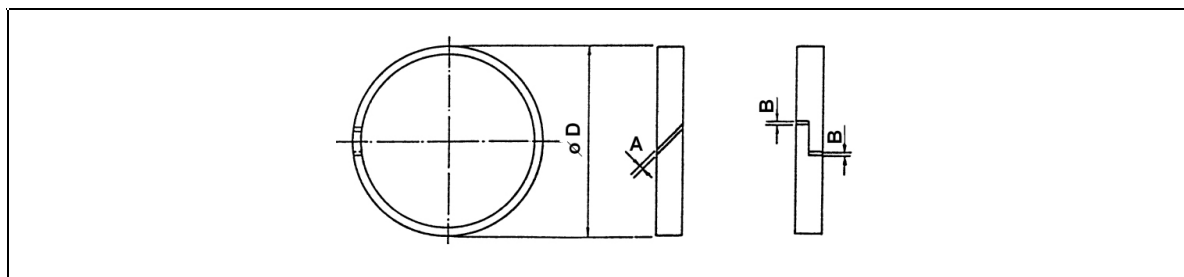

Ø ext D (mm)	Oblique cut A (mm)	Bayonete cut B (mm)	
		Clearance minimum	Clearance maximum
30 a 50	0.10	0.20	0.30
51 a 60	0.15	0.25	0.35
61 a 80	0.20	0.30	0.40
81 a 100	0.25	0.40	0.50
101 a 120	0.30	0.50	0.60
121 a 140	0.40	0.60	0.70
141 a 150	0.60	0.70	0.80
151 a 160	0.70	0.80	0.90
161 a 180	0.80	0.95	1.05
181 a 200	0.95	1.15	1.20

NOTES

- a) Before mounting the segments, it is necessary to carry out the centring, adjustment and expansion according to the tolerances established for each machine and specified in their technical datasheet.
- b) When changing a collar, check it will slide freely to the end of the rotor, taking care that the internal bevel coincides with the fixing pin situated at the apex of the rotor.

TECHNICAL MANUAL

Rotary Vanes | R/RFL G | P/PFL

7. Maintenance and Inspection

- c) The inner race of the bearing must press against the collar, blocking it against the end of the rotor. This race has to be hot fitted (oil 110°C – 120°C), inserting it quickly on the rotor and locking the nut immediately

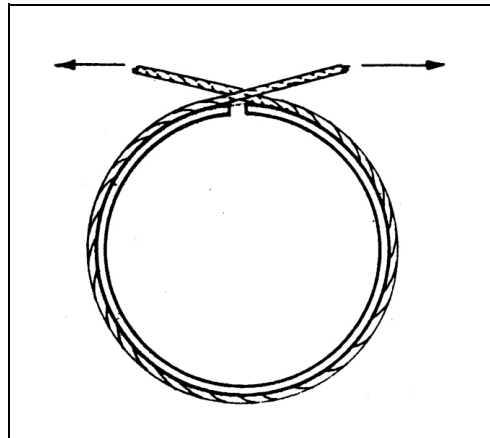

7.4.6. Disassembly

Stripping down a compressor or vacuum pump can lead to any of the following situations:

- a) No part must be changed.
- b) One or several parts – e.g. a cover, stator, rotor, bearing, etc. – must be changed.

Situation (a)

Reassembling the machine will be easier if, during its disassembly, you paid attention to the number and position of adjusting washers in front of the bearing, and if you accurately measured the thickness of the gaskets inserted between the stator and cover in the locking (C) and expansion (D) positions.

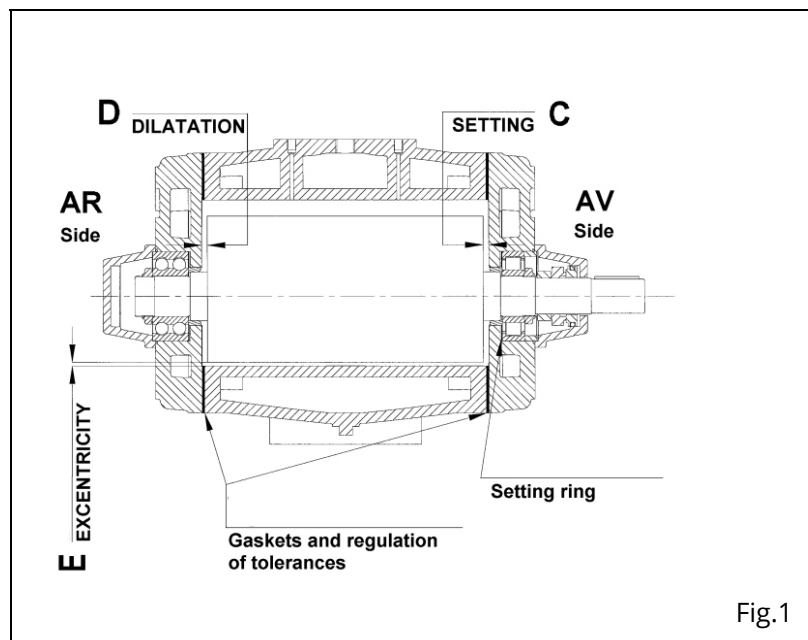

Fig.1

TECHNICAL MANUAL

Rotary Vanes | R/RFL G | P/PFL

7. Maintenance and Inspection

In this event, you will have to insert the adjusting washers in their respective locations and to mount the cover gaskets, increasing their thickness by 20% in relation to the measurements taken during disassembly.

Although not absolutely necessary, it is desirable to check the clearance in the locking (C) and expansion (D) positions. The method for measuring the locking and expansion clearance is described further below.

The bearings supplied by MAPNER have passed strict inspections based on tolerances specific to MAPNER machines. For this reason, the roller tracks of these bearings should never be interchanged.

Situation (b)

When the stator, rotor or covers must be changed, the following operations will be carried out:

- Eccentricity (figure.1) letter (E) - centring
- Locking » (C)
- Expansion » » (D)

If the bearings need be changed, centring will not be done at first, but will be checked once assembly has been completed.

When changing the stator, make sure the discharge nozzles of the new one are exactly fit for the vacuum level or pressure of the original design.

Should there be any changes in the working conditions after the purchase of the machine (pressure, vacuum, rotational speed, etc.), let us know in detail.

Based on the service specific conditions, the mechanized of the stator internal bore can be cylindrical or made eccentrically.

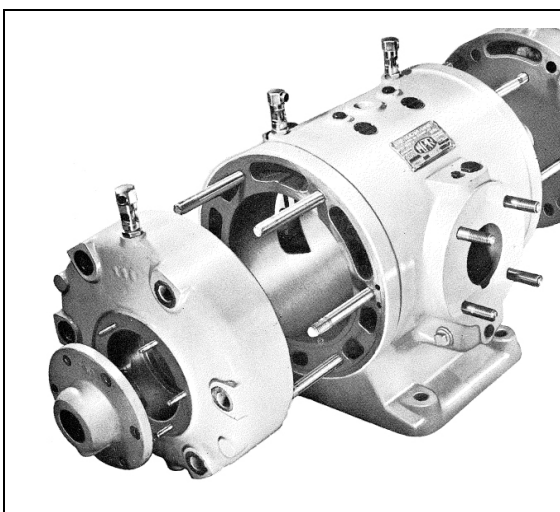

Fig.2

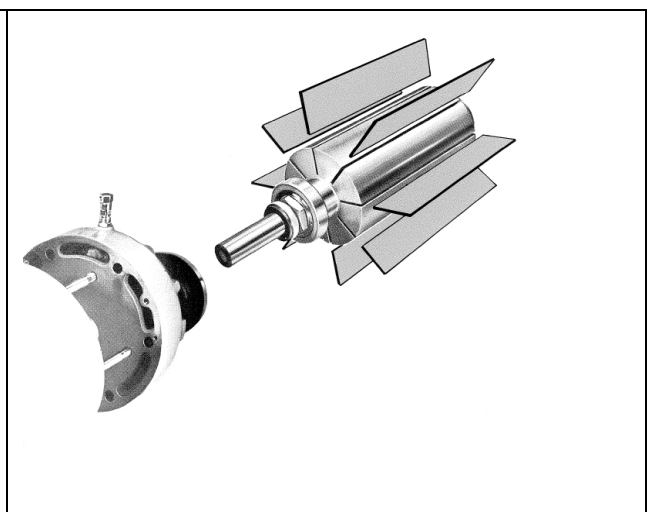

Fig.3

TECHNICAL MANUAL

Rotary Vanes | R/RFL G | P/PFL

7. Maintenance and Inspection

7.4.7. Assembly

7.4.7.1. Eccentricity

7.4.7.2. Calage

7.4.7.3. Dilatation

If repair is not done at MAPNER, remember that it is absolutely necessary and obligatory to smooth out the four edges resulting from the machining along the stator cylinder. Smoothing out the sharp edges at the intersection of the stator cylinder and the inlet and discharge nozzles is also required.

Before starting the assembly, thoroughly clean the stator cylinder and holes as well as the inlet and discharge chambers. Thoroughly clean the rotor slots and surface. Smooth out the external angles of the slots.

Prior to reassembling the machine, systematically check all the parts for perfect condition.

7.4.7.1. Eccentricity

Introduce the rotor into the stator cylinder, laying it on the lower bore. Check to see if the inlet and discharge nozzles are in a correct position.

The eccentricity figure appears on pages 34/37 and 35/37.

Raise the rotor slightly and put a long brass strip underneath; the strip thickness to be equal to the required eccentricity figure.

If the rotor is over 800mm in length, place two brass strips 30mm away from each end of the rotor. Align the front face of the rotor with the stator face in the same plane. Measure the difference in length of rotor and stator at the opposite end in order to be able to distribute the gaskets equally during assembly. Never place the rotor in a position where two slots are along the vertical axis.

Rigorously check the rotor's axial position with regard to the stator axis, by placing a ruler against the stator face and measuring the clearance between the ruler and the rotor. (Fig.1)

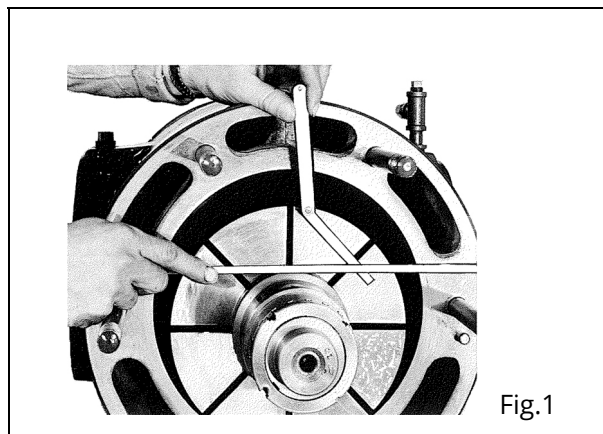

Fig.1

TECHNICAL MANUAL

Rotary Vanes | R/RFL G | P/PFL

7. Maintenance and Inspection

Fix the rotor and block it on the stator base by means of a nut and locknut (Fig. 2).

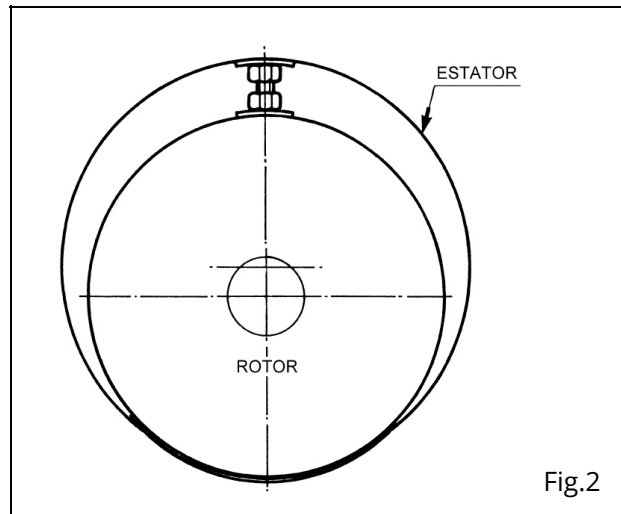

Fig.2

After inserting the cover fixing studs into the stator, fit the covers with their bearings, without any paper gasket between the stator and covers. Check that the bearings are perfectly seated in their housings.

Before tightening the cover fixing nuts, lift each cover vertically.

Doing so will keep the radial play of the bearings in the upper portion. Consequently, the radial play of the rotor will not be less than the specified value, when the metal shims are removed.

With a hand drill, drill two holes parallel to the horizontal rotor axis in the faces of each cover and in the two diametrically opposed hubs. The depth of these holes in the stator shall be 1.5 to 2 times the diameter of the hole. (On models R.300 and above, we recommend using four studs in each cover.) Covers are drilled with a radial or other drilling machine and, once set on the stator, drilling is finished manually using the holes in the covers as guides.

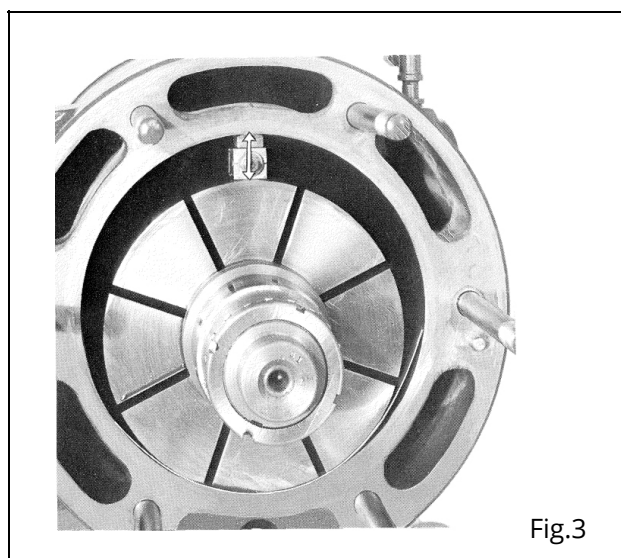

Fig.3

7. Maintenance and Inspection

Clean the holes thoroughly and introduce the elastic pins to a stop.

Loosen and remove the cover fixing nuts and, with extractors, separate the covers from the rotor.

Remove the nuts and locknuts from the rotor and remove the brass strip lying between the rotor and the stator.

Now, reassemble the covers with the bearings and press-fit them in the stator (check to see if the pins are set to a limit).

Fasten the rotor nuts and check for eccentricity. To do so, insert a narrow gauge equal to the eccentricity clearance in thickness, through the inlet or discharge orifice and make it pass between the rotor and the cylindrical bottom of the stator.

The clearance would be too small if the thickness gauge has difficulty passing through and makes the rotor turn. The clearance would be too big if the thickness gauge passes through easily without making the rotor turn.

7.4.7.2 Calage

NH Locking roller bearings

The locking clearance is the gap between the front face of the rotor and the face of the drive side (AV) cover. Due to the total axial play of the locking bearing, the locking clearance can take two values:

- a) a minimum limit
- b) a maximum limit

ASSEMBLY

The difference between the two clearance values, of course, gives the total axial play of the bearing. In pages 34/37 and 35/37 specifies the minimum locking clearance required. This clearance must be rigorously observed.

- 1) Set the cover – with the bearing outer race already mounted without inserting the adjusting washers on the bearing stop – on the rotor.



NOTE

If the bearing supporting collars have compression segments, we recommend that these segments should not be fitted during the setting of the locking clearance. The segments will be fitted once you have verified that the minimum locking clearance is equal to the pages 35/38 and 36/38 specification.

- 2) Introduce the adjustment ring. H J
- 3) Set and tighten the bearing hold-down nut.
- 4) Set the AV front cover without the Cyclam retainer and sealing gaskets.
 - (a) Do not insert the sealing gasket (lead or O-ring).



CAUTION

If the cover has a water jacket, the seals can be inserted between the cover and the water jacket.

TECHNICAL MANUAL

Rotary Vanes | R/RFL G | P/PFL

7. Maintenance and Inspection

- 5) Check the locking clearance. You can do so in any of two ways:
- (a) using a system of ties, butting against the rotor (Fig.1)
 - (b) using a hoisting equipment (Fig. 2-A/B)

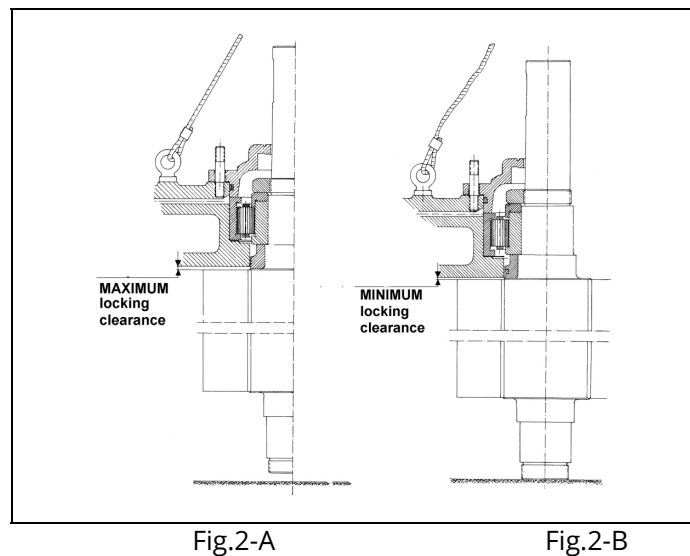
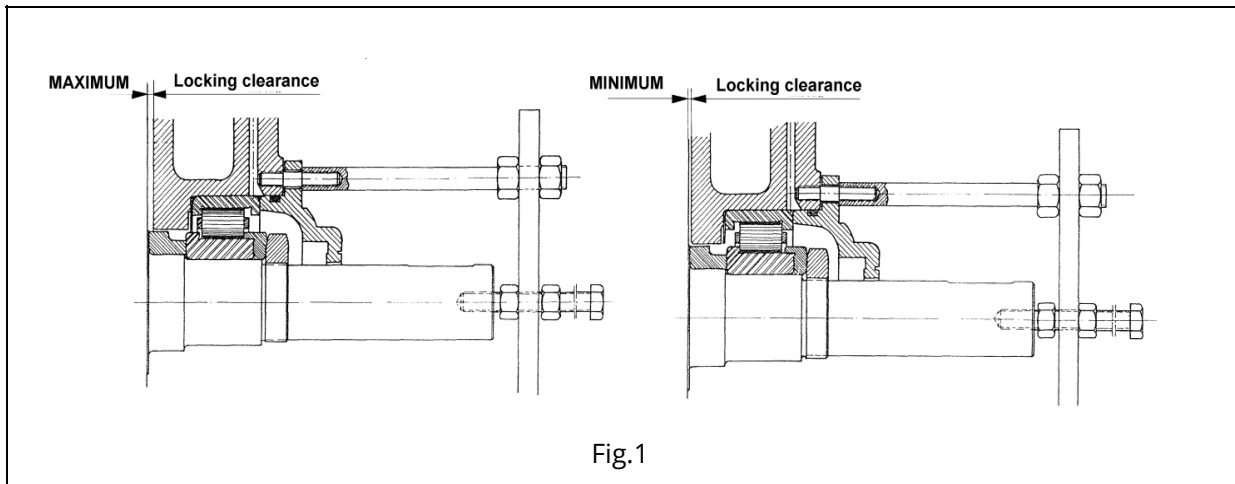

The maximum and minimum locking clearances will be measured by inserting 3 thickness gauges between the cover and rotor, at 120 degrees from each other (see Figure 3).

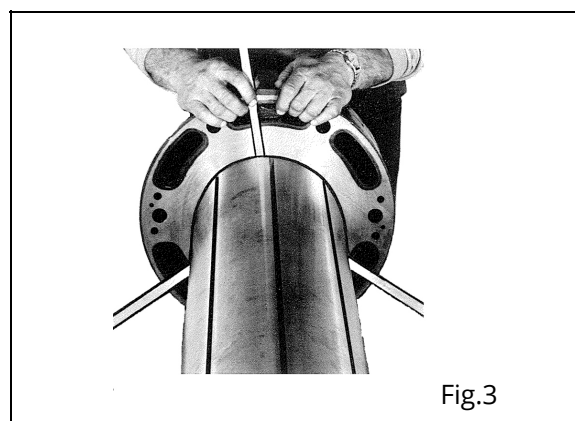

7. Maintenance and Inspection

EXAMPLE: Let the required minimum locking clearance be 20/100 and the measured clearance be 78/100. Then, it would be necessary to insert a 58/100 shim between the outer race of the bearing and the supporting face in the cover.



CAUTION

The greater the number of adjusting washers set between the outer race of the bearing and the supporting face in the cover, the more the locking clearance decreases.

- 6) Measure the gap between the cover flange and the cover with a gauge.
 - (a) covers with a lead gasket must have a clearing in the order of 6 to 8/10
 - (b) as for covers with supporting bush, the clearance shall be 5/10 from the cover.
 - (c) on covers with an O-ring, a maximum clearance of 10/10 shall be maintained.



NOTE

If the interference fit of the cover on the bearing were insufficient, set additional washers on the outer race so as to achieve the specified fit.

- 7) Disassemble the lid and cover to set adjusting washers between the cover and the outer race of the bearing, in order to get the required minimum locking clearance.



NOTE

If the bearing supporting bushes have segments, the segments should not have been inserted into the grooves in the bush until this stage.

- 8) Mount the cover onto the rotor definitively, taking care to join the segment. Next, assemble the retainer and the lid, also in a definitive manner

Fill the bearing box with oil up to half its capacity approximately.

If the rotor fixing nut includes a locking device, the same shall not be blocked until the adjustment has been checked perfectly correct. Verify that the nut has been tightened perfectly (See Figure 4).

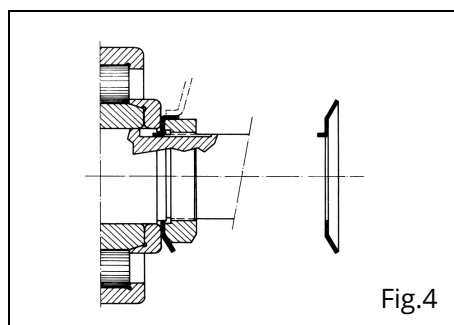

Fig.4

TECHNICAL MANUAL

Rotary Vanes | R/RFL G | P/PFL

7. Maintenance and Inspection

- 9) Measure the minimum and maximum locking clearances using method (a) or (b) in point 6.

This done, the AV front cover, Graphited retainer and lid are definitively fitted to the front end of the rotor. Also the segment, if any, would be fitted into the supporting bush.

7.4.7.3 Dilatation

Generally, the expansion gap is at the back of the machine (AR pump side) and consists of the existing clearance between the rear face of the rotor and the AR rear cover.

Obviously, when locking is done at the rear of the compressor (for special applications, see specific instructions), expansion will take place at the AV front side.

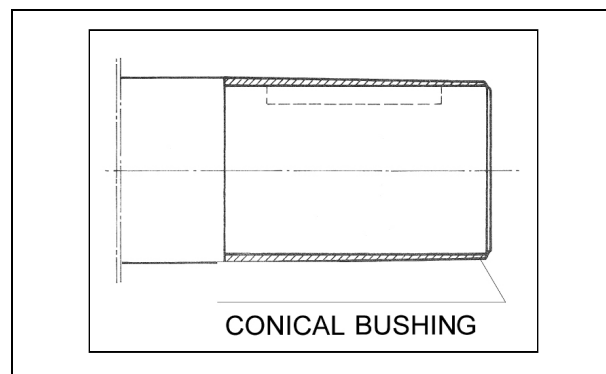

Carefully measure the stator length and the rotor length. Refer to paragraph on 'Eccentricity' 7.4.7 .

The difference between these two measurements plus the total thickness of the gaskets inserted between stator and covers must be equal to the sum of the locking and expansion gaps plus the axial play of the locking bearing. Try to ensure that the thickness of the Klingerit or paper gaskets be the same at the front and rear of the stator.



CAUTION

Bear in mind that the thickness of the paper gaskets decreases by 15 to 20% when squeezed.

In some cases, the total axial play of the locking bearing affects the expansion gap.

In pages 34/37 and 35/37 specifies the expansion gap. To adjust the expansion gap, proceed as follows:

TECHNICAL MANUAL

Rotary Vanes | R/RFL G | P/PFL

7. Maintenance and Inspection

- 1) Set the necessary gaskets on the face on the stator locking side. Oil the gaskets individually and before setting them in place, cut them along the stator bore (the gasket shall not protrude the inside edge of the stator bore) (Fig.5).

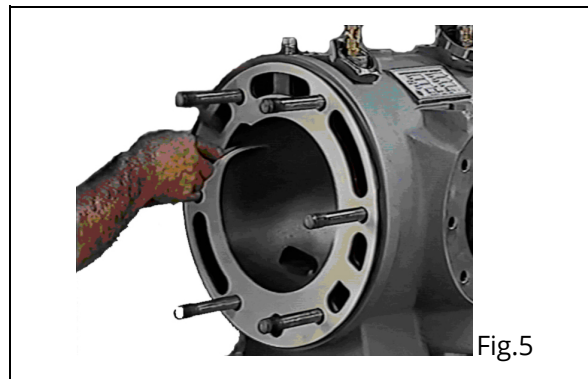

- 2) Introduce the rotor with the AV front cover and lid into the stator.
- 3) Insert the fixing nuts into the adjustment side cover and tighten them.

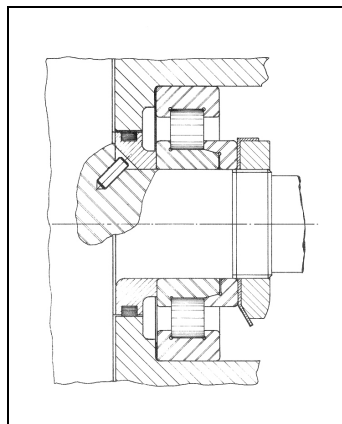

- 4) Place the appropriate amount of gaskets on the expansion side of the stator until the total expansion measure is reached (see table).
- 5) Introduce the outer race of the expansion bearing into the cover.



NOTE

If the bearing supporting bush includes a compression segment, we recommend that this segment is not fitted until the expansion gap has been adjusted. The segment will be put definitively in place after checking that the expansion gap is exactly as per pages 15-06 and 15-07.

- 6) Mount the expansion side cover.

TECHNICAL MANUAL

Rotary Vanes | R/RFL G | P/PFL

7. Maintenance and Inspection

- 7) Insert and tighten the fixing nuts into the cover.
- 8) Push the outer race of the expansion bearing to a stop. Watch the position of the rollers in relation to the inner race of the expansion bearing.
Bear in mind that, during the machine operation, when the rotor has expanded, the bearings must be centred on their inner races. Their position can be rectified by inserting an appropriate number of washers between the outer race of the bearing and the bearing seat in the cover.
- 9) Back off the cover fixing nuts and remove the cover.
- 10) After checking the expansion gap, you can check, if necessary, the centring of the rotor and its faces as well as the faces of the covers and the stator.
- 11) After adjusting the thickness of the Klingerit or paper gaskets on the expansion side, repeat the assembly procedure according to the instructions in points 4/ to 10/.
- 12) If the expansion gap is correct, insert the blades soaked in plenty of oil.



NOTE

If the bearing supporting bushes include compression segments, these are to be inserted at this stage into the grooves in the bush.

- 13) Set the expansion side cover in place again and tighten its fixing nuts.
- 14) Insert and tighten the nut into the rotor. If the nut has a retainer, block it
- 15) Install the AR cover with its sealing gaskets.

TECHNICAL MANUAL

Rotary Vanes | R/RFL G | P/PFL

7. Maintenance and Inspection



CAUTION

Fitting the AR cover is done in the same way as for the AV front cover. If the cover must support the oil pump, take care to check the condition of its coupling, fixing nut and Cyclam retainer. (See figure).

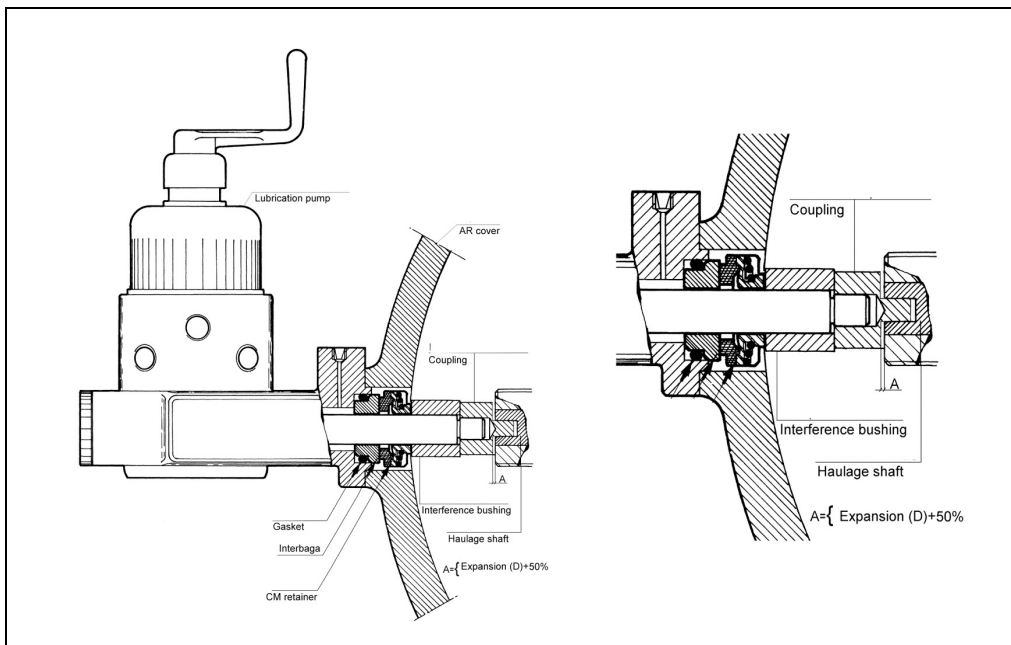

Assembly tolerance scheme of the R/P series compressors, water cooled.

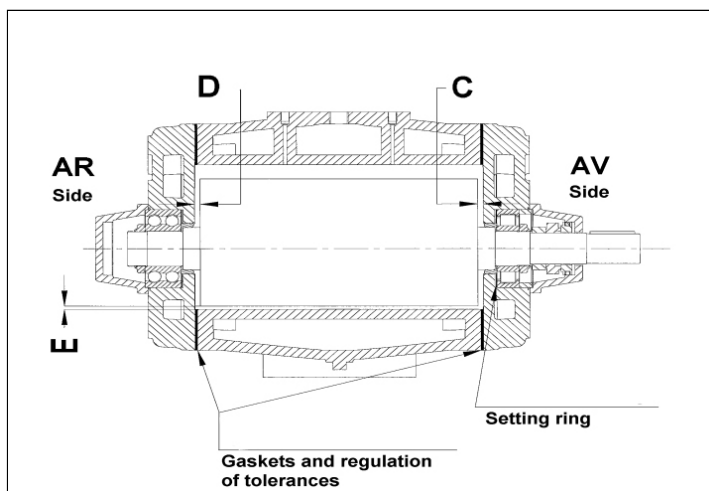

D: Dilatation

C: Calage

E: Excentricity

For intermediate pressure values, please, contact MAPNER.

TECHNICAL MANUAL

Rotary Vanes | R/RFL G | P/PFL



7. Maintenance and Inspection

TIPO		Working at pressure R Series															Vacuum P Series		
		1 bar g			1,5 bar g			2 bar g			2,5 bar g			3 bar g			D	C	E
		D	C	E	D	C	E	D	C	E	D	C	E	D	C	E			
15	min	35	10	15	40	10	15	40	10	15	45	10	15	45	10	15	50	10	15
	max	40	15	20	45	15	20	50	15	20	50	15	20	50	15	20	60	15	20
20	min	35	10	15	40	10	15	40	10	15	45	10	15	45	10	15	50	10	15
	max	40	15	20	45	15	20	50	15	20	50	15	20	50	15	20	60	15	20
20	min	55	10	15	60	10	15	65	10	15	70	10	15	75	10	15	75	10	15
	max	65	15	20	70	15	20	75	15	20	80	15	20	85	15	20	85	15	20
30	min	55	10	15	60	10	15	65	10	15	70	10	15	75	10	15	75	10	15
	max	65	15	20	70	15	20	75	15	20	80	15	20	85	15	20	85	15	20
40	min	65	15	15	75	15	15	80	15	15	85	15	15	90	15	15	90	15	15
	max	75	20	20	85	20	20	90	20	20	95	20	20	100	20	20	100	20	20
50	min	65	15	15	75	15	15	80	15	15	85	15	15	90	15	15	90	15	15
	max	75	20	20	85	20	20	90	20	20	95	20	20	100	20	20	100	20	20
60	min	70	20	25	80	20	25	95	20	25	100	20	25	105	20	25	105	20	25
	max	80	25	30	90	25	30	105	25	30	110	25	30	115	25	30	115	25	30
70	min	70	20	25	80	20	25	95	20	25	100	20	25	105	20	25	105	20	25
	max	80	25	30	90	25	30	105	25	30	110	25	30	115	25	30	115	25	30
80	min	100	20	25	105	20	25	120	20	25	125	20	25	130	20	25	130	20	25
	max	110	25	30	115	25	30	130	25	30	135	25	30	140	25	30	140	25	30
100	min	100	20	25	105	20	25	120	20	25	125	20	25	130	20	25	130	20	25
	max	110	25	30	115	25	30	130	25	30	135	25	30	140	25	30	140	25	30
120	min	105	20	25	110	20	25	125	20	25	130	20	25	135	20	25	135	20	25
	max	115	25	30	120	25	30	135	25	30	140	25	30	145	25	30	145	25	30
121	min	110	20	25	125	20	25	130	20	25	135	20	25	140	20	25	140	20	25
	max	120	25	30	135	25	30	140	25	30	145	25	30	145	25	30	145	25	30
150	min	120	20	25	130	20	25	150	20	25	160	20	25	170	20	25	170	20	25
	max	130	25	30	140	25	30	160	25	30	170	25	30	180	25	30	180	25	30
180	min	130	25	25	140	25	25	160	25	25	170	25	25	175	25	25	175	25	25
	max	140	30	30	150	30	30	170	30	30	180	30	30	185	30	30	185	30	30
190	min	130	25	25	140	25	25	160	25	25	170	25	25	175	25	25	175	25	25
	max	140	30	30	150	30	30	170	30	30	180	30	30	185	30	30	185	30	30
200	min	130	30	30	140	30	30	160	30	30	170	30	30	175	30	30	175	30	30
	max	140	35	35	150	35	35	170	35	35	180	35	35	185	35	35	185	35	35
201	min	130	30	30	140	30	30	160	30	30	180	30	30	185	30	30	185	30	30
	max	140	35	35	150	35	35	170	35	35	190	35	35	195	35	35	195	35	35
250	min	165	30	30	175	30	30	185	30	30	195	30	30	200	30	30	200	30	30
	max	175	35	35	185	35	35	195	35	35	205	35	35	210	35	35	210	35	35
300	min	265	40	35	275	40	35	285	40	35	300	40	35	310	40	35	310	40	35
	max	275	45	40	285	45	40	295	45	40	310	45	40	320	45	40	320	45	40
400	min	165	30	40	175	30	40	185	30	40	195	30	40	200	30	40	200	30	40
	max	175	35	45	185	35	45	195	35	45	205	35	45	210	35	45	210	35	45
500	min	185	40	40	210	40	40	220	40	40	230	40	40	240	40	40	240	40	40
	max	195	45	45	220	45	45	230	45	45	240	45	45	250	45	45	250	45	45
600	min	280	50	50	290	50	50	300	50	50	310	50	50	320	50	50	320	50	50
	max	270	55	55	300	55	55	310	55	55	320	55	55	330	55	55	330	55	55

Assembly tolerance scheme of the RFL/PFL compressors, air cooled.

TECHNICAL MANUAL

Rotary Vanes | R/RFL G | P/PFL

7. Maintenance and Inspection

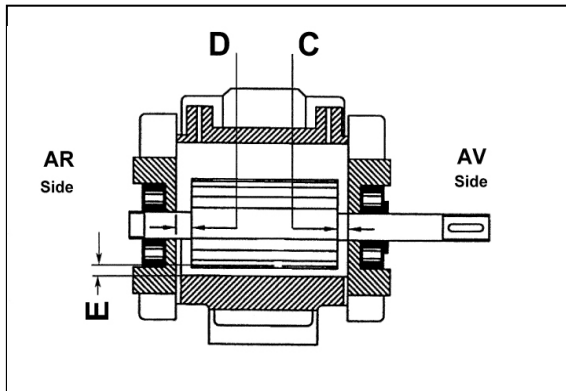

D: Dilatation

C: Setting

E: Excentricity

For intermediate pressure values, please, contact MAPNER.

TType		Working at pressure RFL Series															Vacuum PFL Series		
		0.5 bar g			1 bar g			1.5 bar g			2 bar g			2.5 bar g			D	C	E
		D	C	E	D	C	E	D	C	E	D	C	E	D	C	E			
9	min	15	5	10	20	5	10	25	5	10	30	5	10	30	5	10	30	5	10
	max	20	10	15	25	10	15	30	10	15	35	10	15	35	10	15	35	10	15
15	min	20	10	10	30	10	10	35	10	10	35	10	10	40	10	10	40	10	10
	max	25	15	15	35	15	15	40	15	15	40	15	15	45	15	15	45	15	15
20	min	20	10	10	30	10	10	35	10	10	35	10	10	40	10	10	40	10	10
	max	25	15	15	35	15	15	40	15	15	40	15	15	45	15	15	45	15	15
25	min	35	10	10	50	10	10	55	10	10	60	10	10	65	10	10	70	10	10
	max	40	15	15	55	15	15	60	15	15	65	15	15	70	15	15	75	15	15
30	min	35	10	10	50	10	10	55	10	10	60	10	10	65	10	10	70	10	10
	max	40	15	15	55	15	15	60	15	15	65	15	15	70	15	15	75	15	15
40	min	50	10	15	60	10	15	65	10	15	70	15	15	75	15	15	80	15	15
	max	55	15	20	65	15	20	70	15	20	75	15	20	80	20	20	85	20	20
50	min	60	10	15	70	10	15	75	10	15	85	15	15	90	15	15	95	15	15
	max	65	15	20	75	15	20	80	15	20	90	20	20	95	20	20	100	20	20
60	min	70	10	15	80	10	15	85	10	15	95	15	15	100	15	15	105	15	15
	max	75	15	20	85	15	20	90	15	20	100	20	20	105	20	20	110	20	20
250	min	25	10	20	30	10	20	35	10	20	40	15	15	45	15	15	50	15	15
	max	30	15	25	35	15	25	40	15	25	45	20	20	50	20	20	55	20	20
500	min	50	10	20	55	10	20	60	10	20	65	15	15	70	15	15	75	15	15
	max	55	15	25	60	15	25	65	15	25	70	20	20	75	20	20	80	20	20
750	min	70	15	20	80	10	20	85	10	20	95	15	15	100	15	15	105	15	15
	max	75	20	25	85	15	25	90	15	25	100	20	20	105	20	20	110	20	20

7.4.8.- Cleaning of the refrigeration chamber

The cleaning of the cooling chambers will be done according to a sequence that will be determined according to the nature of the water used. It must be regulated in each case, depending on the real situation and until the cleaning water comes out clean.

To carry out the operation correctly, make quick openings/closures of valve no. 1 so that the air/water mixture causes the emulsion of the sludge accumulated in the chamber and allow its exit out of the machine. Valve no. 2 will be opened completely during the operation.

TECHNICAL MANUAL

Rotary Vanes | R/RFL G | P/PFL

7. Maintenance and Inspection



CAUTION

The air pressure must always be higher than the water pressure, being as maximum 3 bar.

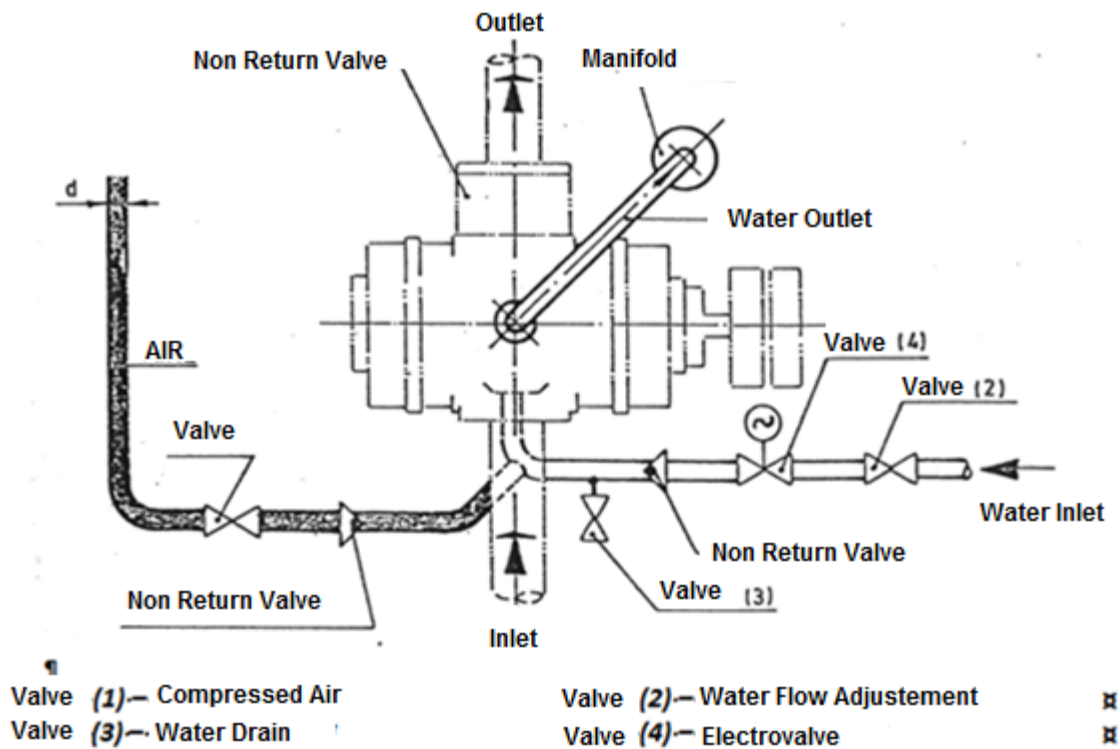

MODEL	PIPE DIAMETER
R.1a R.1600	d=1/2"

7. Maintenance and Inspection

7.5. Maintenance for Extended Inactivity Period

The machines which remain inactive after the preliminary field tests require special attention and must follow specific maintenance operations, to ensure a correct working in the future.

because the accumulation of condensates within the compressor core can cause damage to the rotating parts due to oxidation as well as the blocking of the blades on the rotor housing.



CAUTION

In this situation, the accumulation of condensates within the compressor core can cause damage to the rotating parts due to oxidation as well as the blocking of the blades on the rotor housing.
Warranty does not apply in oxidation cases.



To avoid it, following operations must be done:

- Isolate the machine from the fluid piping.
- Eliminate the condensates through the draining points.
- Drain oil from the bearing housings. For this purpose, remove the plugs from the bottom of the end covers.
- Replace the plugs and regrease the bearings manually, by turning the handle of the oil pump. In case of pump with independent motor, start it until the oil reaches the internal part of the machine.
- Introduce a quantity of oil and anti-rust product into the compressor core.
- Turn the compressor driving pulley manually. Repeat this operation periodically, every 15/20 days of inactivity.
- Whenever there is a risk of frost in the working site area, drain the coolant from the compressor core. This applies only to water-cooled compressors.
- Apply rust-preventer on the external machined surfaces liable to undergo oxidation.
- Cover the equipment with a plastic protector.
- Before putting the compressor unit in normal service, read and follow the start-up section of the instruction manual.

TECHNICAL MANUAL

Rotary Vanes | R/RFL G | P/PFL

8. Troubleshooting

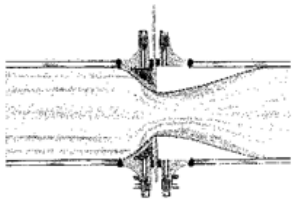
FAULT	• POSSIBLE CAUSES	• SOLUTION
<p>Overheating of the blower core.</p> 	<ul style="list-style-type: none"> • Increase in differential pressure. • Inlet blockage • Insufficient ventilation. • Insufficient cooling. 	<ul style="list-style-type: none"> • Check operating pressure. • Check aspiration filter and installation. • Verify the ventilation system. • Check cooling system and water circulation.
<p>Unusual noise during the operation.</p> 	<ul style="list-style-type: none"> • Damaged bearings. • Transmission misalignment. • Transmission rubbing on the guard. • Friction between pistons or with the stator. • Dirt adhering to the pistons. • Foreign bodies in the fluid chamber. 	<ul style="list-style-type: none"> • Change them. • Check and align correctly. • Check and correct. • Check for correct clearance. • Clean. • Inspect and remove if any.
<p>Fluid/Oil/water leakage</p> 	<ul style="list-style-type: none"> • Damaged seal. • Cracked lubricator or damaged gasket. • Damaged gaskets • Leakage lubrication system • Leakage through installation connections • Leakage through safety valve 	<ul style="list-style-type: none"> • Replace. • Replace. • Replace. • Check oil pump and connection points. • Check and replace if necessary. • Check safety valve and/or working conditions.
<p>Insufficient inlet flowrate</p> 	<ul style="list-style-type: none"> • The flowrate required for operation differs from the requested specification. • Air escape through the tubes. • Clogged filter. • Air escape through the machine at rest. • Insufficient speed. • Wear and clearances out of range • Real working conditions different to those from design. 	<ul style="list-style-type: none"> • Check the blower's performance characteristics. • Check for leaks in the pipes. • Clean or replace. • Check the non-return valves. • Check. • General revision of the machine. • Contact with MAPNER Technical Department.

TECHNICAL MANUAL

Rotary Vanes | R/RFL G | P/PFL

8. Troubleshooting

FAULT	POSSIBLE CAUSES	SOLUTION
<p>Energy consumption of drive motor too high.</p> 	<ul style="list-style-type: none"> • The operating conditions do not conform to those specified in the order. • Incipient seizing due to mechanical friction. • Mechanical or electrical damage of the motor. • Voltage drop or phase shift in the mains. • Incorrect connection of the motor. 	<ul style="list-style-type: none"> • Check data. • Inspect the blower core. • Overhaul by manufacturer. • Check the mains voltage on the terminals. • Check and correct motor connection.
<p>Non rotating effect after stopping the blower.</p>	<ul style="list-style-type: none"> • Non-return valve damaged or blocked. 	<ul style="list-style-type: none"> • Check and change it if necessary.



CAUTION

If you observe any trouble, stop the machine immediately, check for the possible causes and repair as appropriate.

Upon completion of the repair, check for free rotation of the drive shaft. Also check for correct operation after restarting the machine.

TECHNICAL MANUAL

Rotary Vanes | R/RFL G | P/PFL

9. Annexes

10.1 Three-phase cage motors



CAUTION

All the conductive parts of the equipment must be placed in such a way that a potential difference does not exist between them.

Star connection

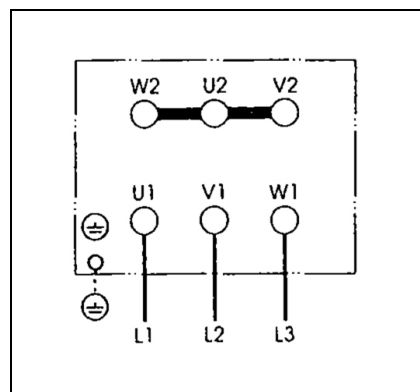

Delta connection

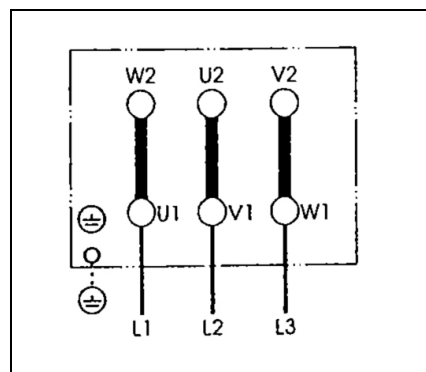

Connection to star-delta starter

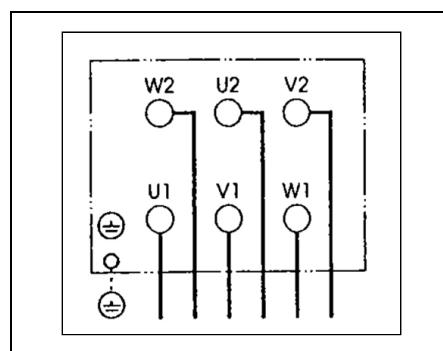

9. Annexes

PTC Thermal protector

Thermal protectors in the bobbins heads



CAUTION

Do not apply a voltage higher than 2,5 V

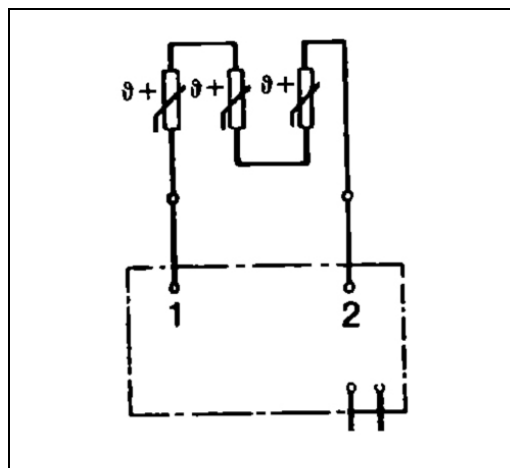

Heating resistance

Resistance in bobbins heads

OBSERVATION

The electric drive motors installed in explosive atmospheres must be equipped with thermal protectors.

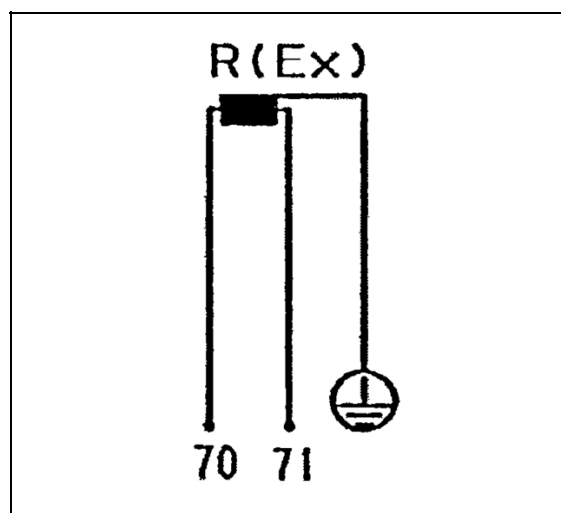

TECHNICAL MANUAL

Rotary Vanes | R/RFL G | P/PFL



9. Annexes

( ) Star-delta starter

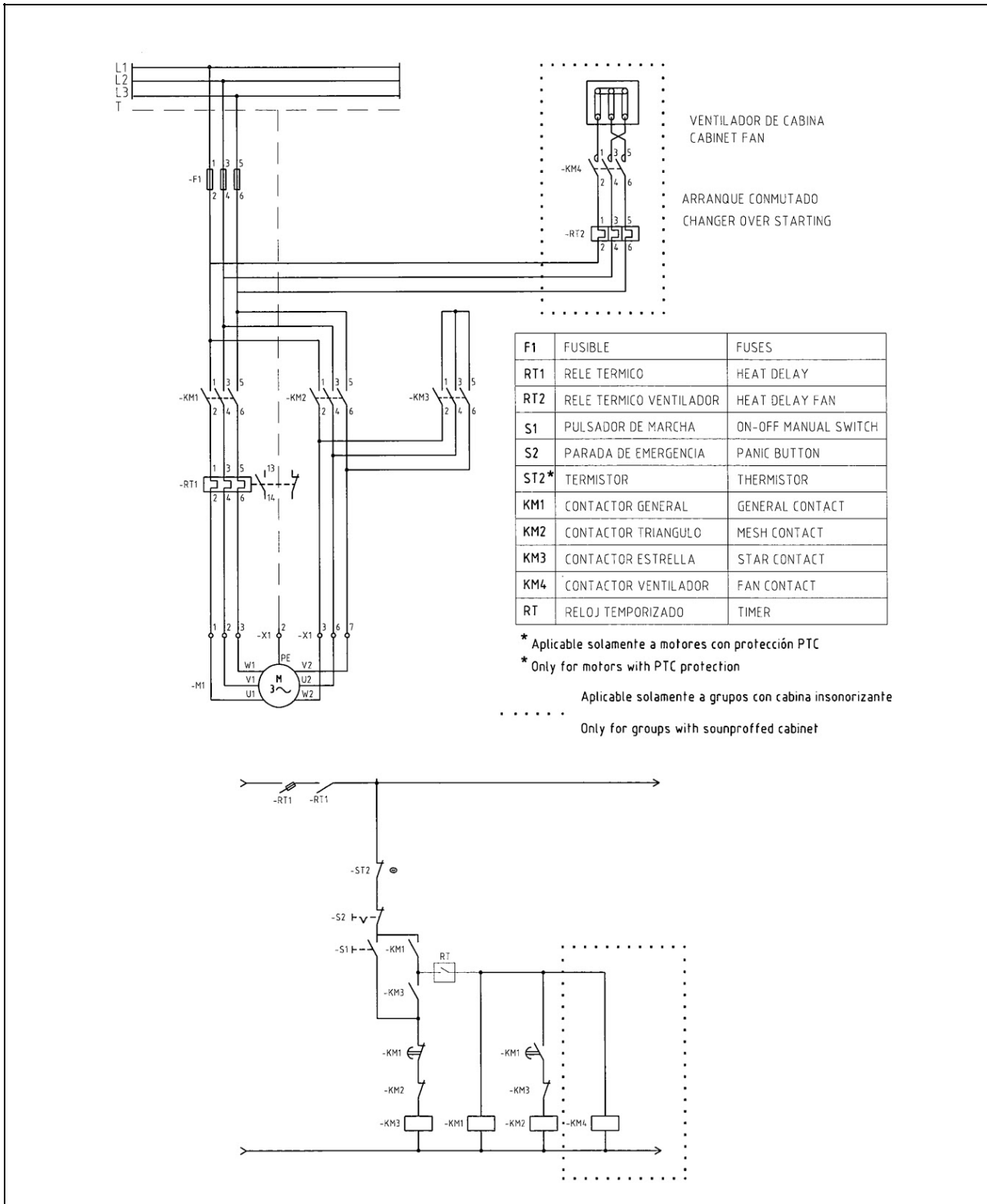



MAQUINAS PNEUMATICAS ROTATIVAS XXI, S.L.U.

Headquarters

Polígono Industrial Zamoka
Oialume Bidea 21
20115 Astigarraga, Gipuzkoa
Spain, Europe

Contact

T: + 34 943 335 100
F: + 34 943 335 480
tecnico@mapner.com

www.mapner.com

GPS: Latitud N 43° 16' 36" Longitud W -1° 57' 5"

Partner

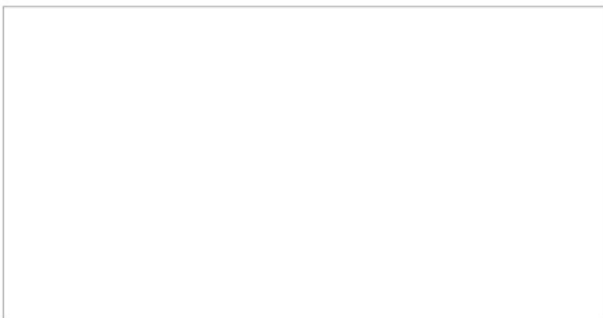

Certifications

